

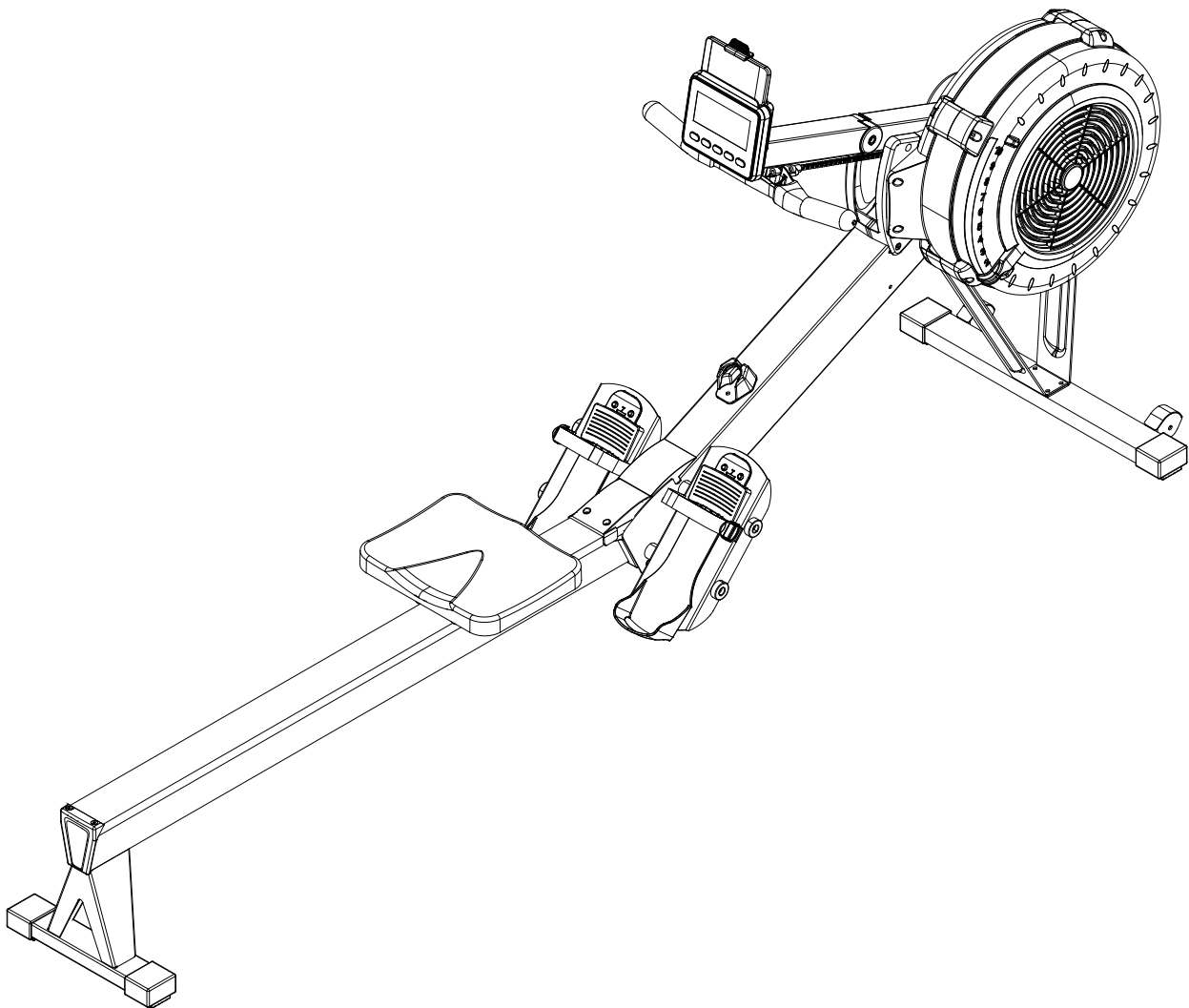

HIT FITNESS

OWNER'S MANUAL



Product May Vary Slightly From Pictured.

Item No: HIT00797-HIT FITNESS 2 ROWER

TABLE OF CONTENTS

Safety Instructions	2	Storage	26
Before You Begin	3	Product Parts Drawing	27
Hardware Identification Chart	4	Parts List.....	28
Assembly Instructions	6		
Computer Instructions	12		
Operational Instructions	19		
Maintenance	21		

SAFETY INSTRUCTIONS

1. To reduce the risk of serious injury, read the following Safety Instructions before using the **ROWER**.
2. Save these instructions and ensure that other exercisers read this manual prior to using the **ROWER** for the first time.
3. Read all warnings and cautions posted on the **ROWER**.
4. The **ROWER** should only be used after a thorough review of the Owner's Manual. Make sure that it is properly assembled and tightened before use.
5. We recommend that two people be available for assembly of this product.
6. Keep children away from the **ROWER**. Do not allow children to use or play on the **ROWER**. Keep children and pets away from the **ROWER** when it is in use.
7. It is recommended that you place this exercise equipment on an equipment mat.
8. Set up and operate the **ROWER** on a solid level surface. Do not position the **ROWER** on loose rugs or uneven surfaces.
9. Make sure that adequate space is available for access to and around the **ROWER**.
10. Before using, inspect the **ROWER** for worn or loose components, and securely tighten or replace any worn or loose components prior to use.
11. Before using, check the condition of the CHAIN(36). Replace the CHAIN(36) if it is cracked or broken.
12. Consult a physician prior to commencing an exercise program and follow his/her recommendations in developing your fitness program. If at any time during exercise you feel faint, dizzy, or experience pain, stop and consult your physician. Failure to follow all warnings and instructions could result in serious injury or death.
13. Always choose the workout which best fits your physical strength and flexibility level. Know your limits and train within them. Always use common sense when exercising.
14. Do not wear loose or dangling clothing while using the **ROWER**.
15. Never exercise in bare feet or socks; always wear proper footwear such as running, walking, or cross training shoes that fit well, provide foot support, and feature non-skid rubber soles.
16. Be careful to maintain your balance while using, mounting, dismounting, or assembling the **ROWER**, loss of balance may result in a fall and bodily injury.
17. Do not use the SEAT(51) to move the **ROWER**. The SEAT(51) will move and the SEAT CARRIAGE(10) may pinch your hand or fingers. When assembling or separating the unit, keep all children away and make sure your hands are clear of any pinch point.
18. The **ROWER** should not be used by persons weighing over 297 lbs /135 kgs.
19. The **ROWER** should be used by only one person at a time.

BEFORE YOU BEGIN

Thank you for choosing the **ROWER**. We take great pride in producing this quality product and hope it will provide many hours of quality exercise to make you feel better, look better, and enjoy life to its fullest.

It's a proven fact that a regular exercise program can improve your physical and mental health. Too often, our busy lifestyles limit our time and opportunity to exercise. The **ROWER** provides a convenient and simple method to begin your journey of getting your body in shape and achieving a happier and healthier lifestyle.

Before reading further, please review the drawing below and familiarize yourself with the parts that are labeled.

Read this manual carefully before using the **ROWER**.

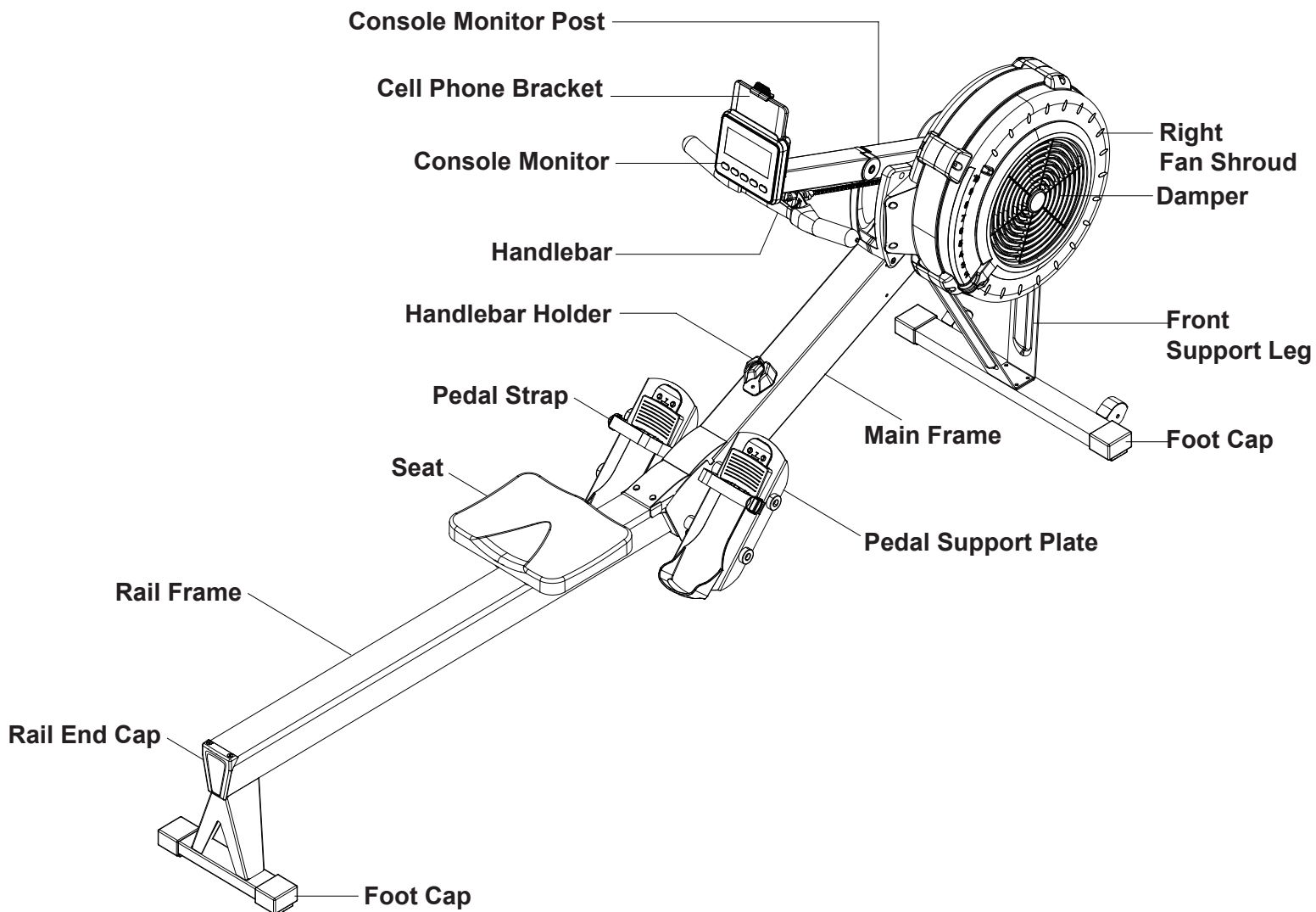

THE FOLLOWING TOOLS ARE INCLUDED FOR ASSEMBLY :

 **Allen Wrench (6mm)**
Allen Wrench (5mm)

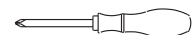
 **Screwdriver**

 **Wrench**

HARDWARE IDENTIFICATION CHART

This chart is provided to help identify the fasteners used in the assembly process. Place the washers or the ends of the bolts or screws on the circles to check for the correct diameter. Use the small scale to check the length of the bolts and screws.

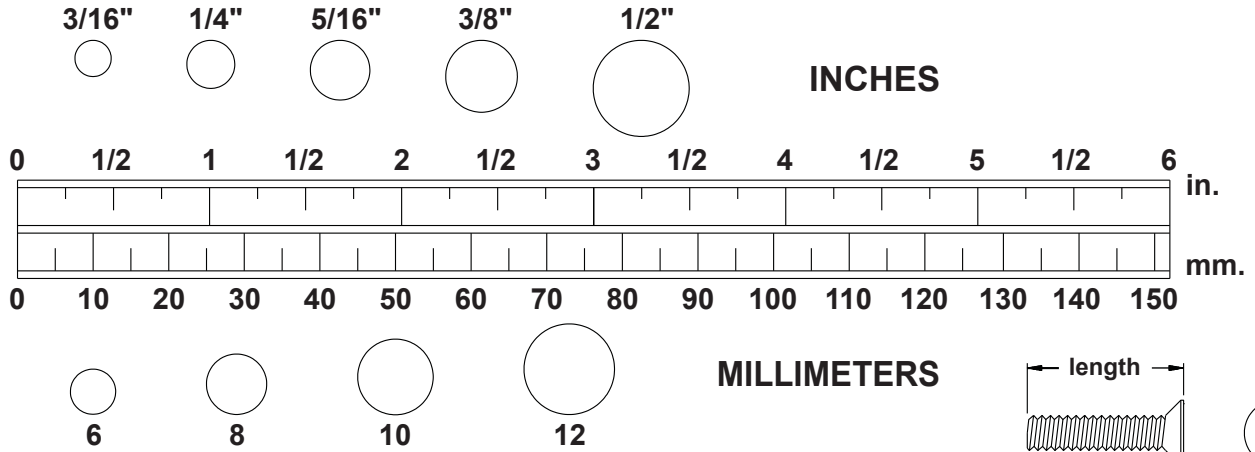



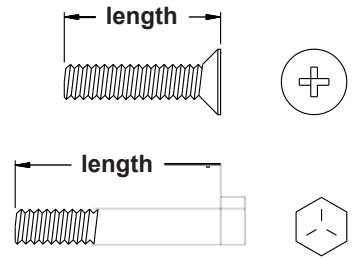



NOTICE: The length of all bolts and screws, except those with flat heads, is measured from below the head to the end of the bolt or screw. Flat head bolts and screws are measured from the top of the head to the end of the bolt or screw.

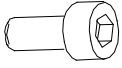
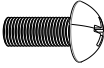
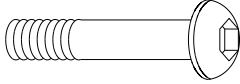
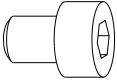

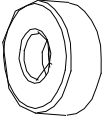
After unpacking the unit, open the hardware bag and make sure that you have all the following fasteners. Some fasteners may be already attached to the parts.

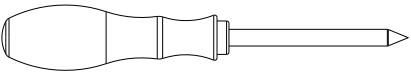
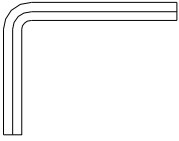
MAIN BODY ASSEMBLY FASTENERS

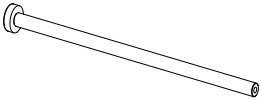
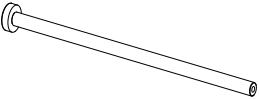
Picture	code	Part Number and Description	Qty
	173	Socket Head Cap Screw (M8X20)	2
	131	Phillips Pan Head Screw (M6X12)	2
	78	Button Head Cap Screw (M8x 75mm)	1
	81	Socket Head Cap Screw (M6 x 16mm)	8
	79	Washer (M8)	1
	76	Washer (M6)	8
	98	Pull Pin	1
	178	Foot Pedal End Cap	2
	80	Nylon Lock Nut, M8	1
	102	Screwdriver	1
	103	Allen Wrench ,6mm	2
	114	Allen Wrench, 5mm	1
	104	Wrench	1
	139	Pedal Shaft, 16mm	1
	140	Pedal Shaft, 12mm	1

ASSEMBLY INSTRUCTIONS

STEP 1

First, take out the packing materials **Cardboard (A)** and **Cardboard (B)**. Then flip them over so the sides with carved letter are facing up. Take the **Main Frame (175)** out from the carton and put it on both **Cardboard (A & B)** as picture shown. The **Right and Left Fan Shrouds (43 & 44)** should be placed in the groove of **Cardboard (B)**.

NOTE: Fan Shrouds will be easily damaged if the whole product is placed on the ground directly during the assembly.

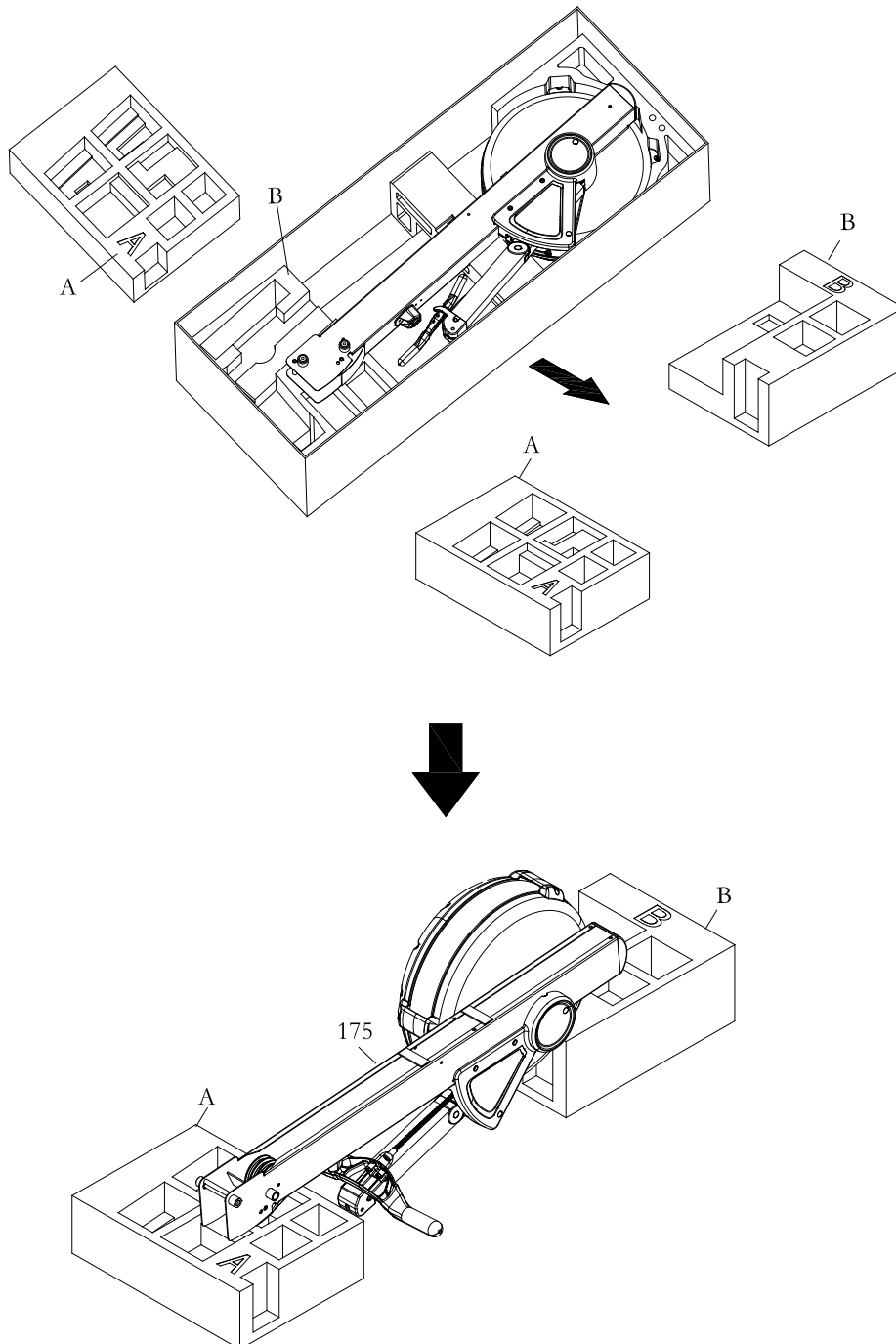

ASSEMBLY INSTRUCTIONS

STEP 2

Attach **Front Support Leg A(7)** and **Front Support Leg B(8)** to **Front Stabilizer(4)** using: 4 PCs of **M6X16mm Socket Head Cap Screw(81)** and **M6 Flat Washer(76)**.

NOTE: Do not fully tighten bolts until instructed.

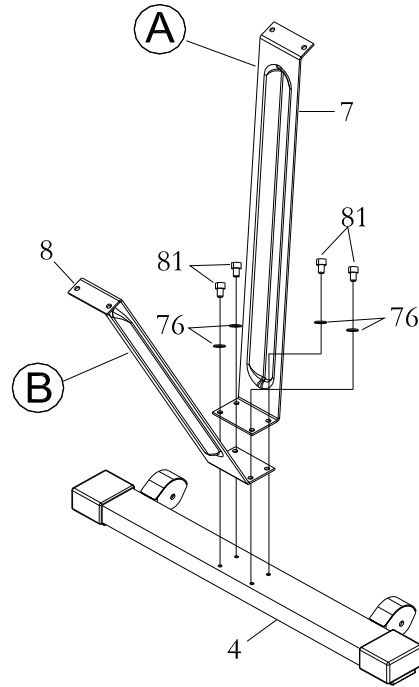
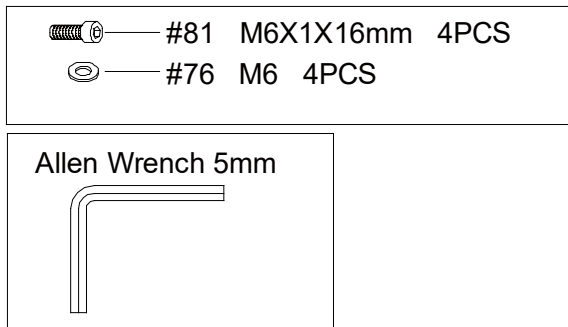

STEP 3

Attach **Front Support Leg A(7)** and **Front Support Leg B(8)** to **Main Frame(175)** using: 4 PCs of **M6X16mm Socket Head Cap Screw(81)** and **M6 Flat Washer(76)**.

Note: Complete this step before taking the item out from its packing material Cardboard (A & B)

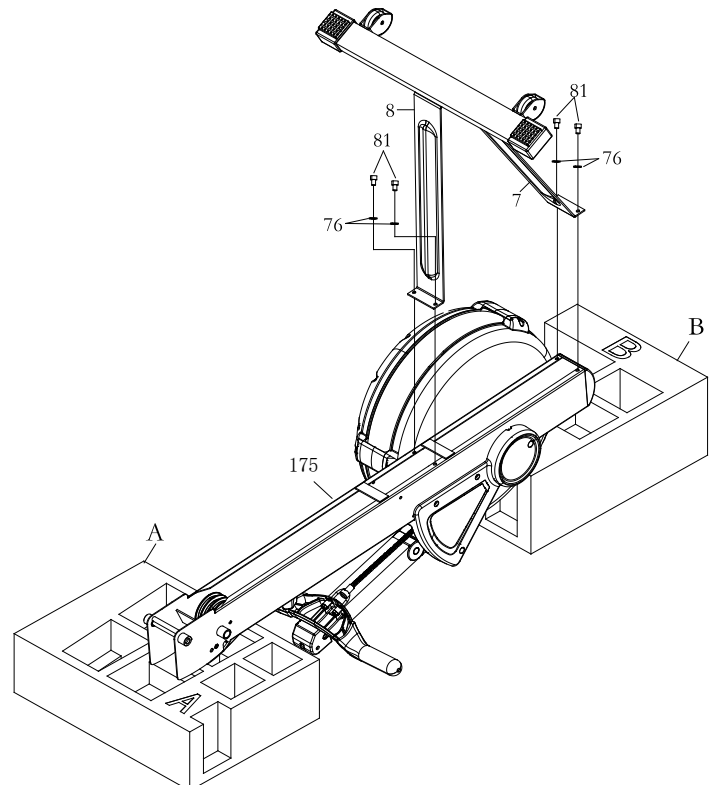
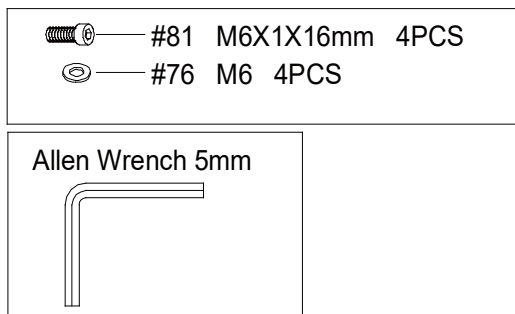

ASSEMBLY INSTRUCTIONS

STEP 4

Lift up the **Main Frame(175)**. Insert the **Pedal Shaft 16mm(139)** and **Pedal Shaft 12mm(140)** in sequence from left **Pedal Support Plate(177)** to **Main Frame(175)** and then from right **Pedal Support Plate(177)** to **Main Frame(175)**.

Tighten above parts using: 2 PCs of **M8x20mm Socket Head Cap Screw(173)** and **Foot Pedal End Cap(178)**.

NOTE: Fully tighten all bolts at the end of this step.

 #173 M8X1.25X20mm 2PCS

Allen Wrench 6mm 2PCS

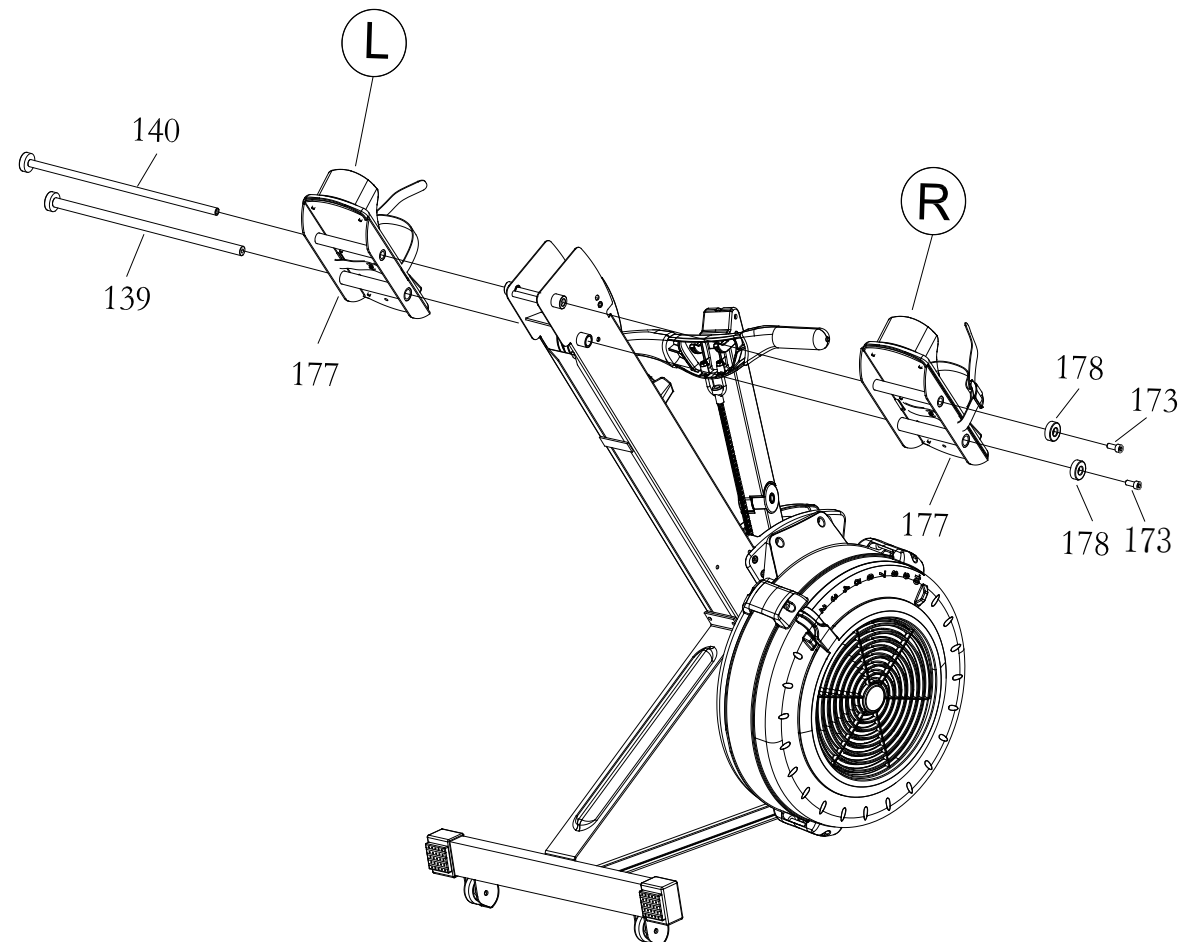

ASSEMBLY INSTRUCTIONS

STEP 5

One hand holds the **Pedal Strap(47)** and lifts up the **Main Frame(175)**, while the other hand lifts up the **Rail Frame(176)**. Insert the **Rail Frame(176)** into the **Main Frame(175)**. Make the **Pedal Shaft 12mm(140)** fit into the gap in the **Rail Frame(176)**. Finally, insert the **Pull Pin(98)** into the **Main Frame(175)**.

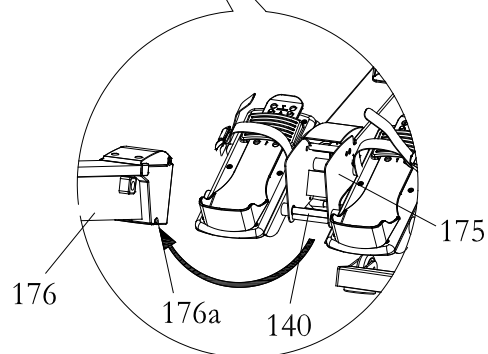
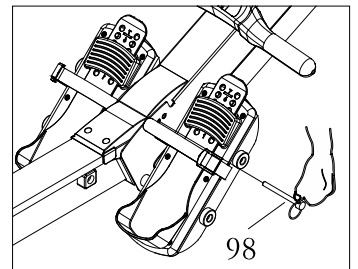
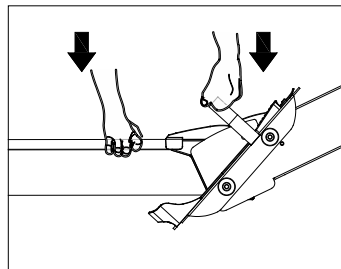
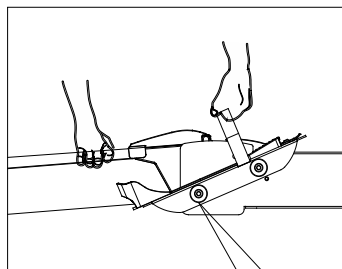
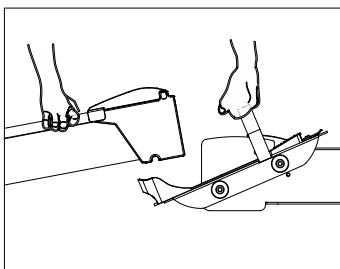
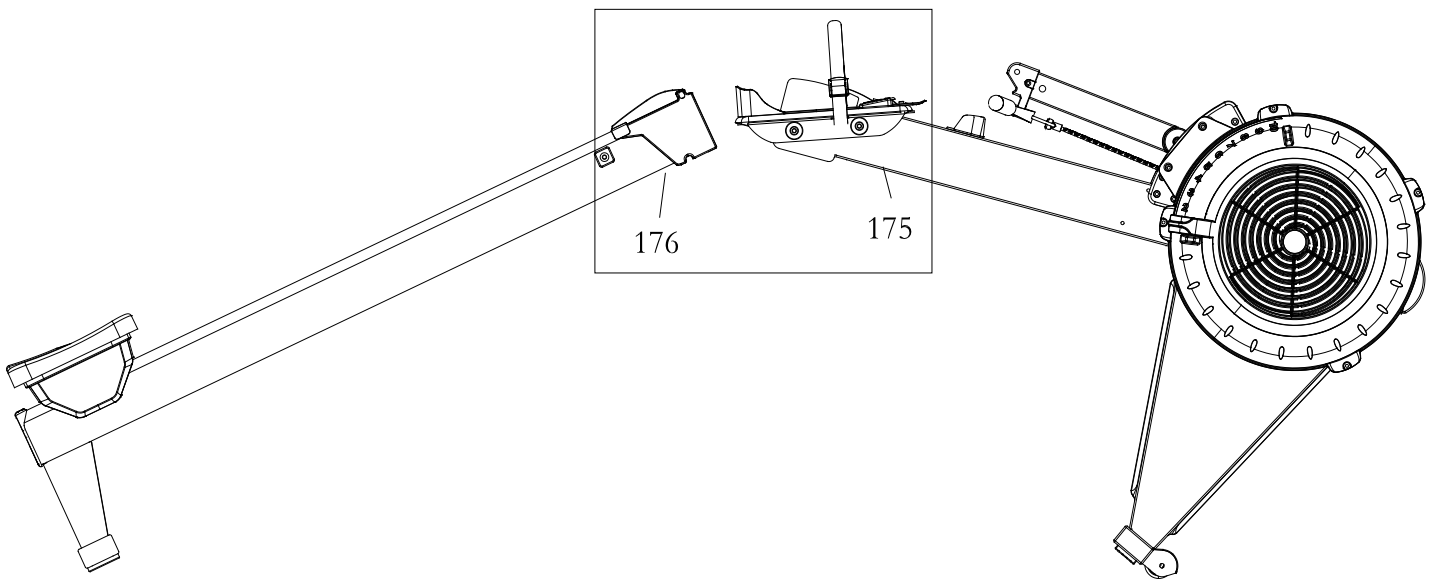

ASSEMBLY INSTRUCTIONS

STEP 6

Lift up the **Lower Console Monitor Post(135)**. Attach the **Lower Console Monitor Post(135)** on **Left/ Right Side Cover(57/ 58)** by using: 1PC of **M6x12mm Phillips Pan Head Screw(131)**

NOTE: Fully tighten bolts at end of this step.

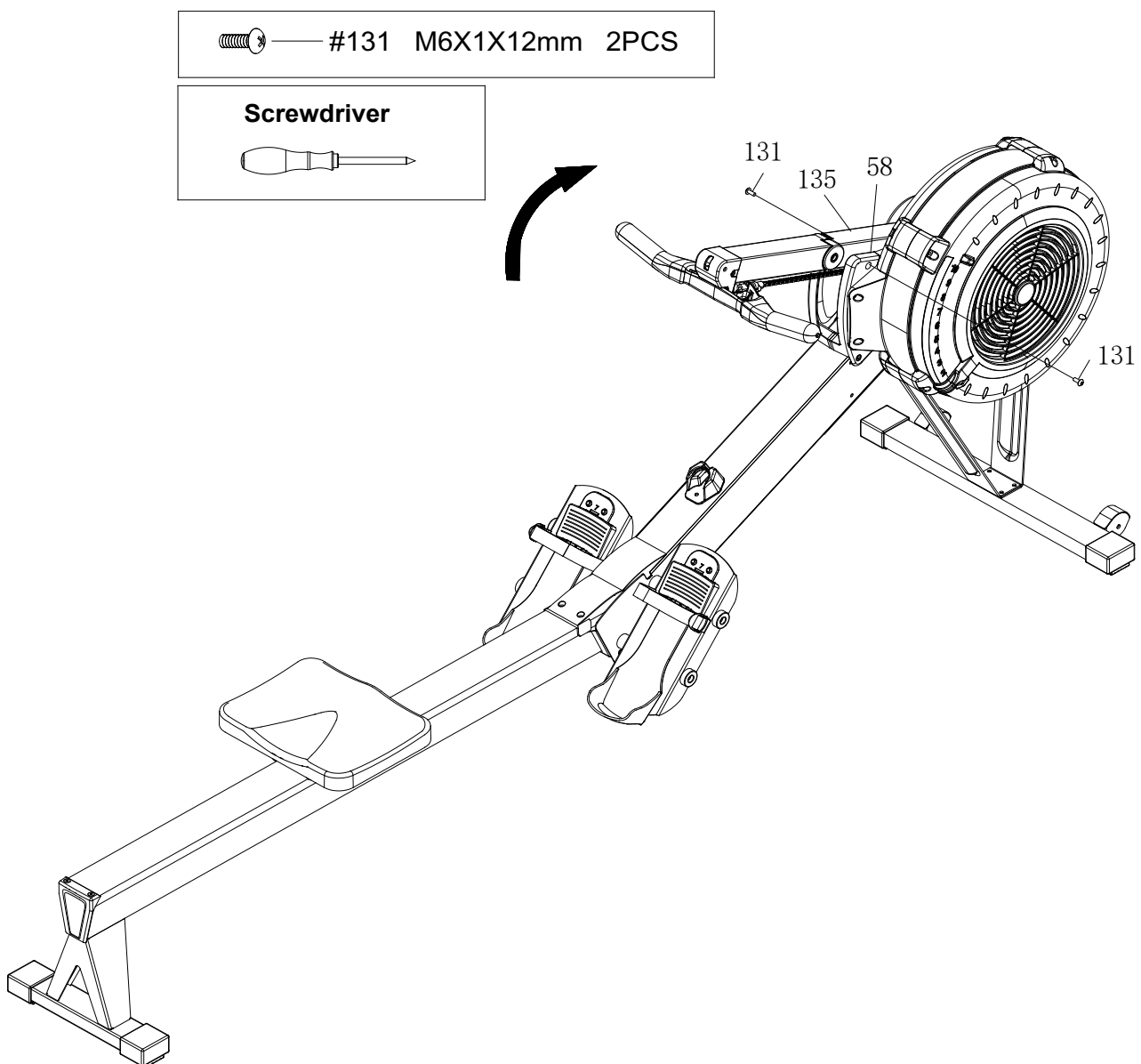

ASSEMBLY INSTRUCTIONS

STEP 7

Attach the Console Monitor(19) to the Console Mounting Bracket(179) by using: 1 PC of M8x75mm Button Head Cap Screw(78), M8 Flat Washer(79), and M8 Nylon Lock Nut(80).

STEP 8

Connect Sensor Cable(23) into the back of the Console Monitor(19a).

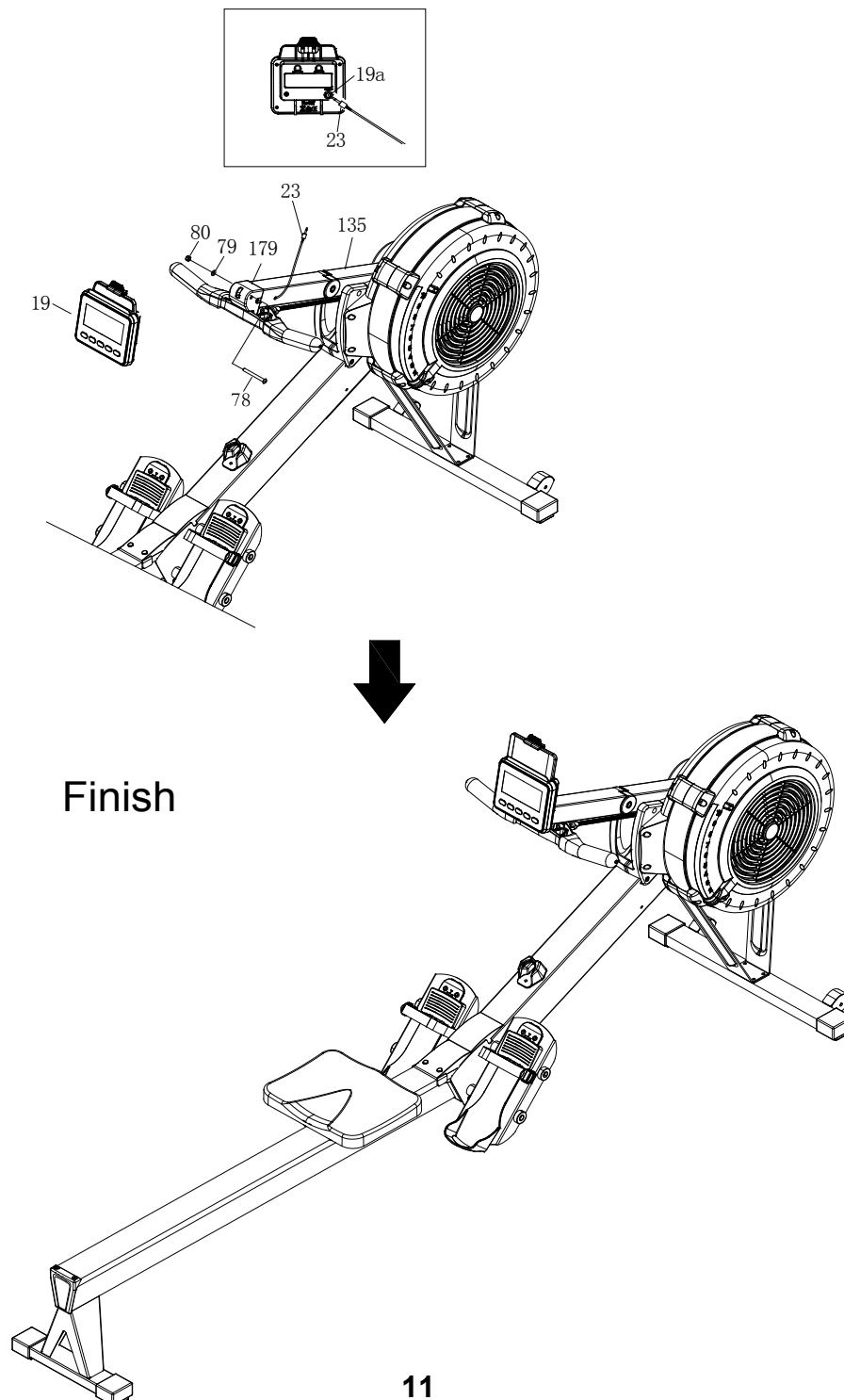

COMPUTER INSTRUCTIONS

Your AIR ROWER utilizes an air fan system to create resistance for your workout. We recommend that you use this computer console to vary your workout from session to session and note your progress toward your fitness goals. When used regularly in this way, the computer console can become an important source of motivation which will help keep you on track.



COMPUTER INSTRUCTIONS

Back View

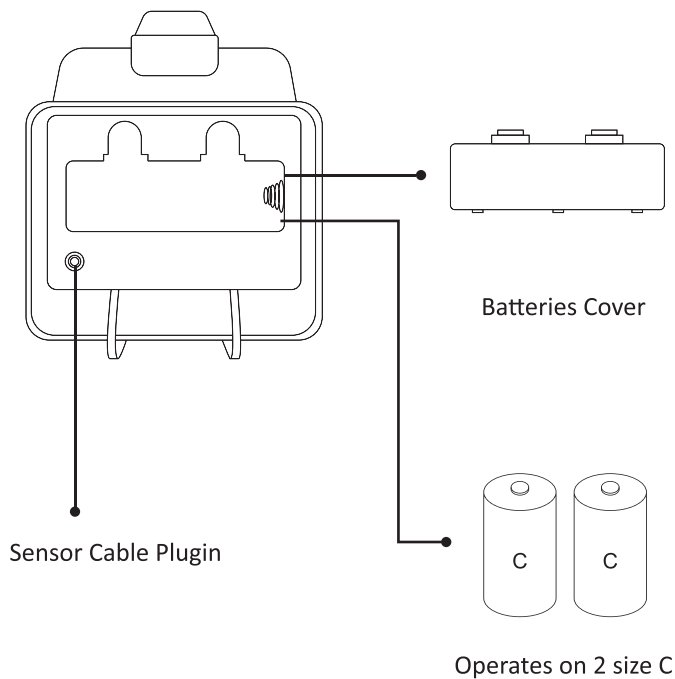

Front View

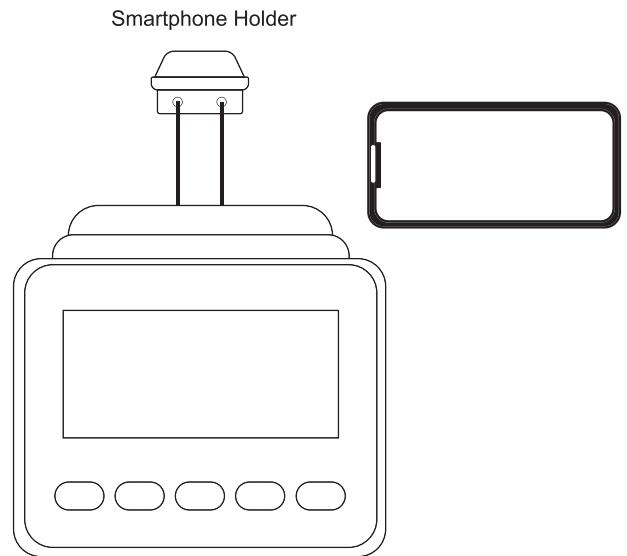

Your ROWER utilizes an air fan system to create resistance for your workout. We recommend that you use this computer console to vary your workout from session to session and note your progress toward your fitness goals. When used regularly in this way, the computer console can become an important source of motivation and interest which will help keep you on track.

Initial Setup

POWER ON

- Move the handlebar to start exercising in Quick Start Program or press any button to go into IDEL mode.
- When there is no batteries installed, monitor can still work in Quick Start Program.

POWER OFF

- In IDEL mode, monitor will automatically shut off after 20 seconds of inactivity.
- When running an interval program, monitor will automatically shut off after 2 minutes of inactivity.
- In all other programs, monitor will automatically shut off after 30 seconds of inactivity.
- Monitor will not shut off when connecting to Bluetooth.

Function Buttons

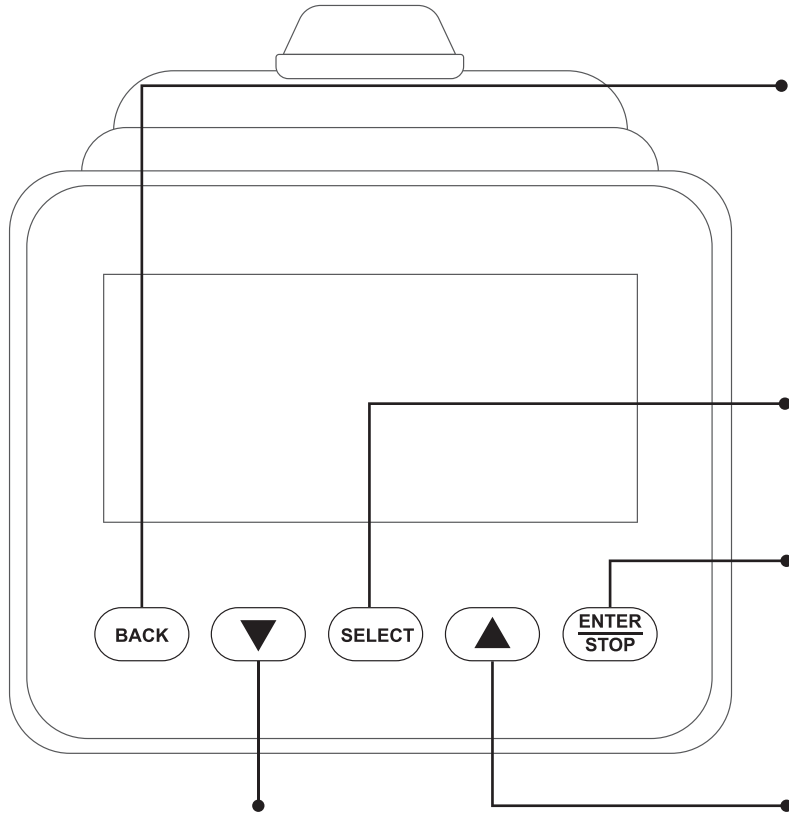

BACK BUTTON:

- When selecting the programs, press the button to return to the previous program.
 - When you finish a running program, press the button to jump into the IDEL mode.
-

SELECT BUTTON:

- In IDLE mode, press and release SELECT to cycle through each program option. Stop on the program of your choosing.

NOTE: Default exercising mode is Quick start program.

.....

ENTER/STOP BUTTON:

- When selecting the programs and presetting target values, press the button to confirm.
 - Press the button and hold it down for three seconds to reset all functions to zero and restart the computer.
-

▼ DOWN BUTTON :

- Press to decrease the preset values. Press the button and hold it down, the presetting value will go faster, release the button to stop.
-

▲ UP BUTTON :

- Press to increase the preset values. Press the button and hold it down, the presetting value will go faster, release the button to stop.

During exercise, when back light is turned off, the first pressing of any button will turn on the back light. When the back light is still lit, press STOP button the first time to pause the counting of all function values. Press STOP button the second time to view the workout summary. Press STOP button the third time to go back to IDLE mode.

COMPUTER INSTRUCTIONS

Console Display

PULSE

- Display the heart rate from 40 to 220 beats per minute during exercise. To use this function, the user must wear Heart Rate Chest Strap.

STROKE RATE

- Display the current stroke per minute during exercise.
- The lightened up semi-circle equals to the stroke rate that displayed in numbers. The more grids it shows, the higher your stroke rate is.

BLUETOOTH

- Display Bluetooth icon at the upper side of monitor screen when monitor is connected to an app.

TIME

- Total workout time

TIME/500m & TIME/500m AVG

- The estimated (average) time for reaching 500 meters based on your current stroke rate.

WATTS

- Display the amount of power generated at any moment during the workout.

DIST & DIST/30min

- DIST is the distance accumulated in the exercise (meter only).
- DIST/30min is the estimated distance for 30 minutes based on current stroke rate.

CAL & CAL/HOUR

- CAL display the amount of calories burnt in the exercise.
- CAL/HOUR display the estimated calories burnt in an hour.

WATTS AVG

- Display the average watts during the exercise.

CYCLE

- Display different cycles in the interval programs.

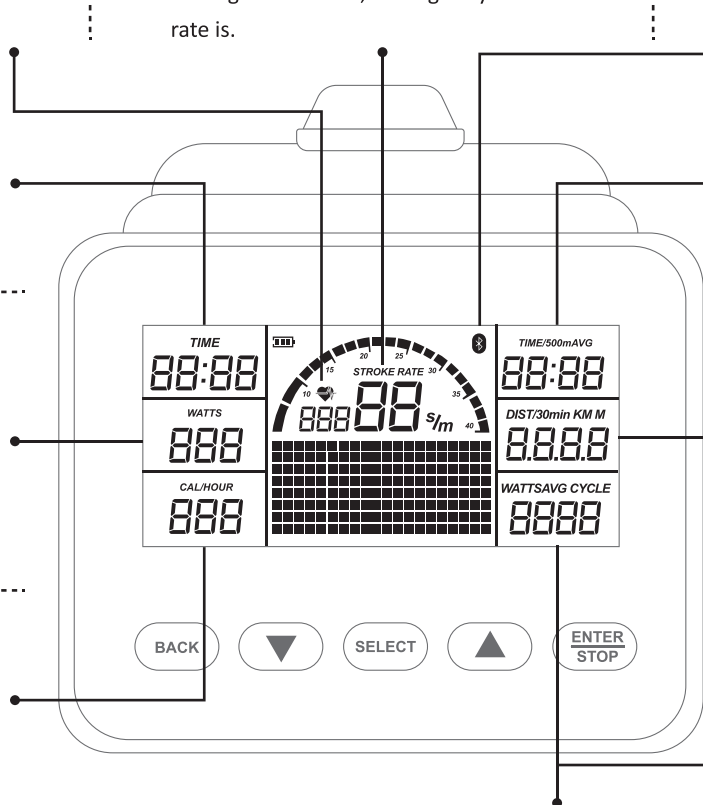

LOW BATTERY

- Display battery symbol only when the battery is low.

SUMMARY

- Press ENTER/STOP button for 2 times to enter summary mode.
- When user pulls Handlebar (3) in summary mode, monitor resumes back to display all data with a "beep" sound.

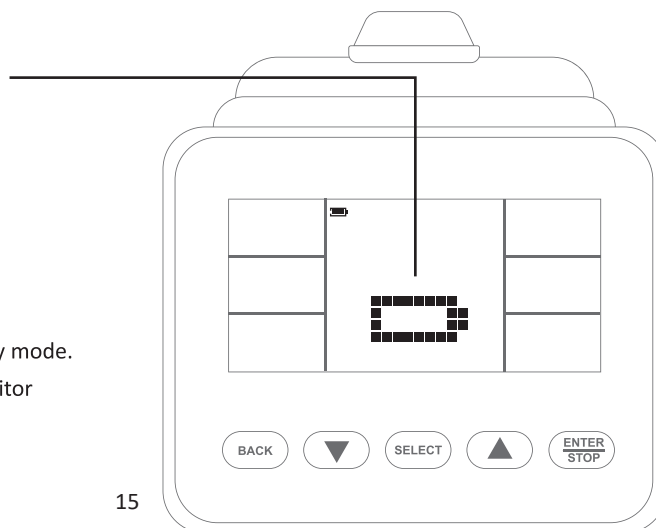

COMPUTER INSTRUCTIONS

PROGRAMS

The console monitor has 8 programs. Press **SELECT** to change workout programs according to the following sequence.

Quick Start Program > Distance Countdown > Time Countdown > Calories Countdown > Game > 20/10 Interval > 10/20 Interval > 10/10 Customize Interval

1. QUICK START PROGRAM

To Quick Start the program, you can pull on the Handlebar(3) to start. All function values for the console will count up.

- Press "STOP" button once to temporarily stop counting all values (Pause function). Pull the Handlebar (3) again to continue the counting. Long press "STOP" button to delete all counting data.
- For Quick Start and all three countdown programs, press "SELECT" button to choose the data displayed in the same display window, including Time & Time/500m AVG.
- For the other seven programs, press "BACK" button to enter IDLE mode. Or press and hold "ENTER/STOP" button for over 3 seconds to re-start the console. Use "SELECT" button to toggle between programs. Use "UP" and "DOWN" buttons to adjust the value and press "ENTER/STOP" to confirm.

2. DISTANCE COUNTDOWN PROGRAM

During the workout, the "DISTANCE" program will count down from preset value.

- The program will start once the user pulls the Handlebar(3). When the program is finished, the monitor will show "WINNER" with an audible alarm. Press the "BACK" button to go to the IDLE mode.

3. TIME COUNTDOWN PROGRAM

- During the workout, the "TIME" program will count down from preset value. The program will start once the user pulls the Handlebar(3). When the program is finished, the monitor will end with an audible alarm. Press "BACK" button to go to the IDLE mode.

4. CALORIES COUNTDOWN PROGRAM

- During the workout, the "CALORIES" program will count down from preset value. The program will start once the user pulls the Handlebar(3). When the program is finished, the monitor will show "END" with an audible alarm. Press "BACK" button to go to the IDLE mode.

COMPUTER INSTRUCTIONS

PROGRAMS

The console monitor has 8 programs. Press **SELECT** to change workout programs according to the following sequence.

Quick Start Program > Distance Countdown > Time Countdown > Calories Countdown > Game > 20/10 Interval > 10/20 Interval > 10/10 Customize Interval

5. GAME PROGRAM

- When the "GAME" program is selected, the program will start once the user pulls the Handlebar. There is no presetting value to be entered. When the program is finished, the monitor will show your score with an audible alarm. Press the "BACK" button to go to the IDLE mode.

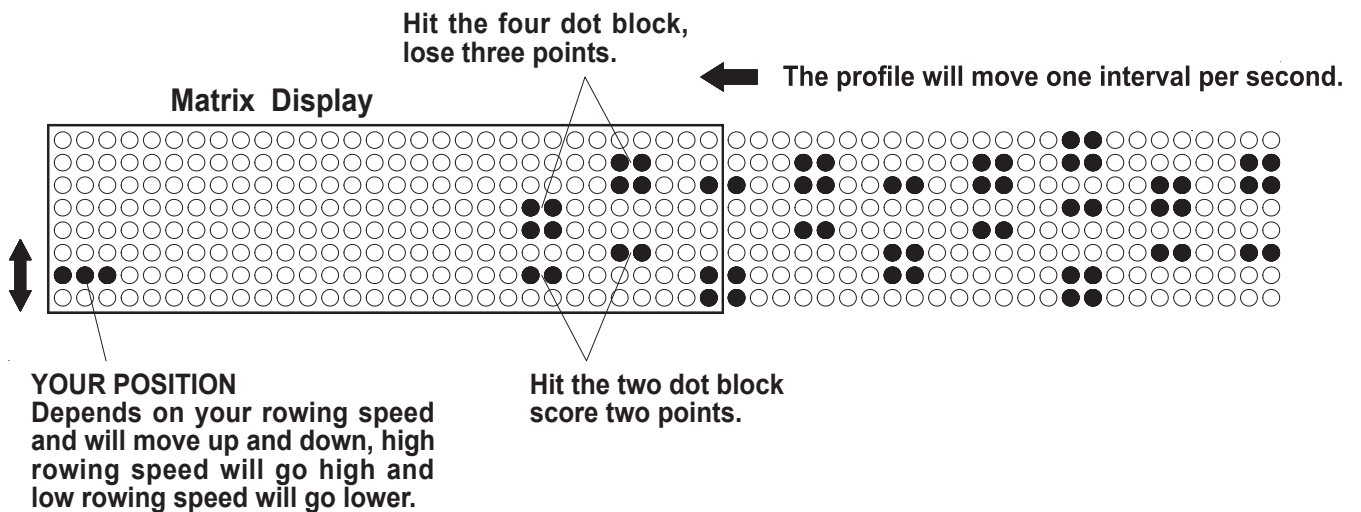

6. 20/10 INTERVAL PROGRAM

- When it is in the "20/10 INTERVAL" program, the console monitor will display flashing "8" for presetting value of cycle. "20" is 20 seconds for exercising, and "10" is 10 seconds for resting. Then user can use "UP" and "DOWN" buttons to input the value from 1 to 99. The user will workout for 20 seconds and then rest for 10 seconds. When the program is finished, the monitor will end with an audible alarm. Press the "BACK" button to go to the IDLE mode.

7. 10/20 INTERVAL PROGRAM

- When it is in the "10/20 INTERVAL" program, the console monitor will display flashing "8" for presetting value of cycle. Then user can use "UP" and "DOWN" buttons to input the value from 1 to 99. User will workout for 10 seconds and then rest for 20 seconds. The program will start once the user pulls the Handlebar(3). When the program is finished, the monitor will end with an audible alarm. Press the "BACK" button to go to the IDLE mode.

8. 10/10 CUSTOMIZE INTERVAL PROGRAM

- When it is in the "10/10" INTERVAL" program, the console monitor will display flashing "8" for presetting value of cycle. Then user can use "UP" and "DOWN" buttons to input the value from 1 to 99 for number of cycle, workout time, and rest time. The program will start once the user pulls the Handlebar(3). When the program is finished, the monitor will end with an audible alarm. Press the "BACK" button to go to the IDLE mode.

COMPUTER INSTRUCTIONS

BLUETOOTH CONNECTION

Please make sure the console is activated in order to proceed Bluetooth connection with your smart-phone or tablet devices.

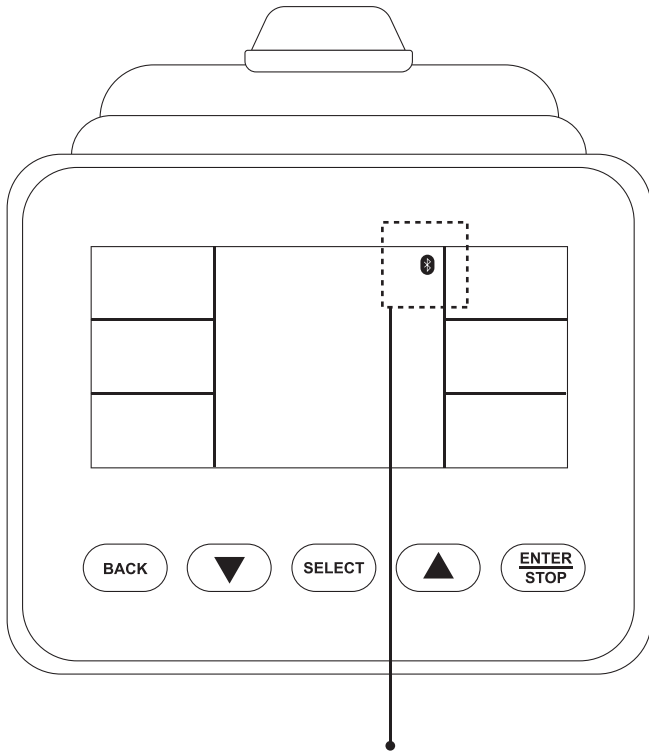

The icon will be displayed at the top right of console screen when it's connected to an app.

AVAILABLE APPS



Kinomap



D-fit

 **BTMS PROTOCOL**

*Please go to settings on your device to allow the apps to access Bluetooth connection.

SCAN TO DOWNLOAD



Android



IOS

OPERATIONAL INSTRUCTIONS

I. LOAD ADJUSTMENT

There is a **Damper(42)** built into the **Right Fan Shroud(43)**. Move the **Indicator** in the **Damper(42)** to point to the numbers on the **Right Fan Shroud(43)** to adjust the load. There are settings from 1 to 10. Setting #1 will provide the lowest resistance. Setting #10 will provide the highest resistance.

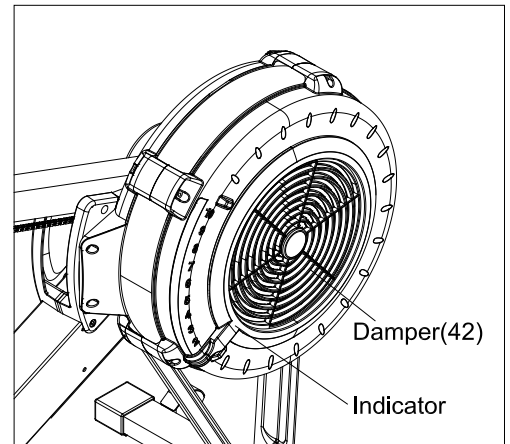

II. HANDLEBAR POSITION

The **Handlebar(3)** can be placed on the hook in the **Console Monitor Post(134)**, refer to illustration A. Or, you can place the **Handlebar(3)** on the **Handlebar Holde (52)** as shown in illustration B.

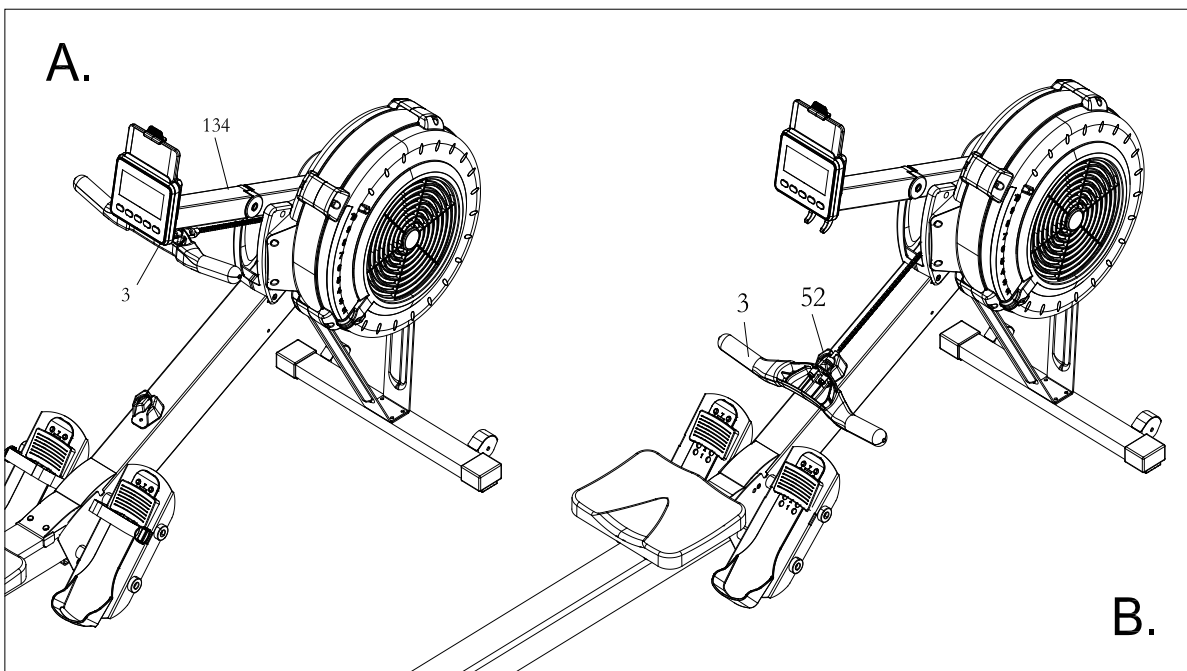

III. PEDAL CAP ADJUSTMENT

The position of the **Foot Pedal(45)** can be adjusted. Refer to the illustration. Pull the **Foot Pedal(45)** out from the two bulges in the **Pedal Support Plate(177)**, then lower or raise the **Foot Pedal(45)** to the desired position. Lock the **Foot Pedal(45)** in position by pressing the adjustment holes of the desired position onto the two bulges.

Refer to the numbers on the **Foot Pedal(45)** to make sure that **Foot Pedal(45)** are adjusted on the same position on both sides.

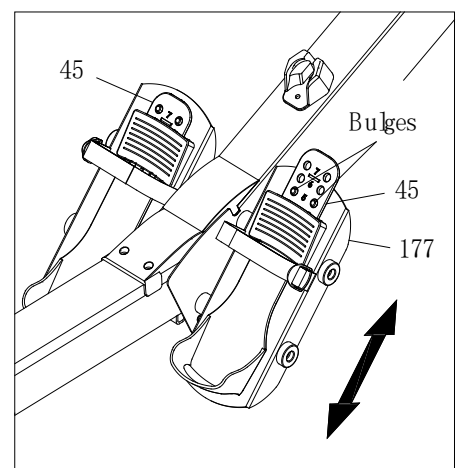

OPERATIONAL INSTRUCTIONS

USING THE CELL PHONE BRACKET

The **Smart Phone Holder(156)** can move up and down. Move up the **Smart Phone Holder(156)**, then slide the Mobile Phone into the gap between the **Smart Phone Holder(156)** and the **Console Monitor(19)**. Move down the **Smart Phone Holder(156)** to clip the Mobile Phone in position.

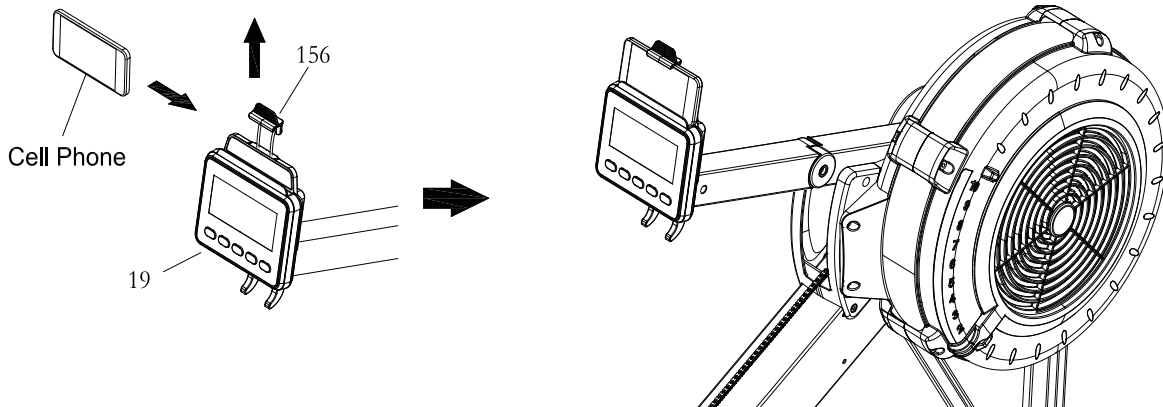

CONSOLE MONITOR POST ADJUSTMENT

Hold the **Console Monitor(19)** by two hands, then adjust the **Upper Console Monitor Post(134)** up and down to the best position for you.

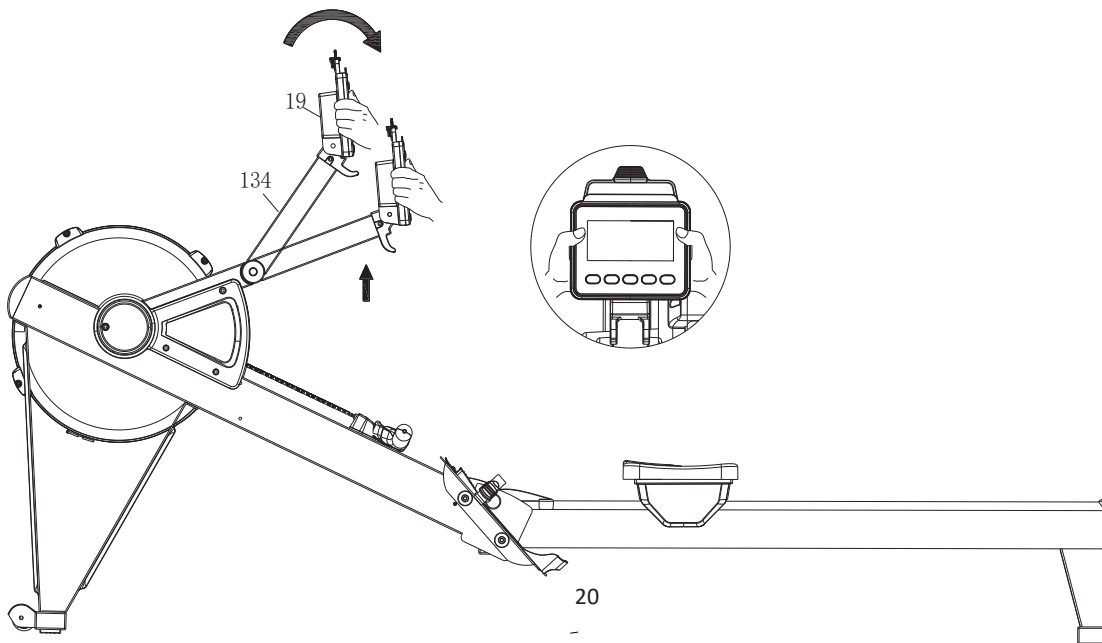

MAINTENANCE

The safety and integrity designed into the **ROWER** can only be maintained when the **ROWER** is regularly examined for damage and wear. Special attention should be given to the following:

1. Pull on the **Handlebar(3)** and verify that the Magnetic System provides tension and the seat travel is smooth and stable.
2. Clean the roller tracks in the **Stainless Steel Rail(14)** with an absorbent cloth.
3. Verify that all nuts and bolts are present and properly tightened. Replace missing nuts and bolts. Tighten loose nuts and bolts.
4. Check the condition of the **Chain(36)**. Replace the **Chain(36)** if it is cracked or broken.
5. It is the sole responsibility of the user/owner to ensure that regular maintenance is performed.
6. Worn or damaged components must be replaced immediately or the **ROWER** removed from service until repair is made.
7. Only Lycan fitness equipmentsupplied components should be used to maintain/repair the **ROWER**.
8. Keep your **ROWER** clean by wiping it off with an absorbent cloth after use.

CONSOLE MONITOR POST ADJUSTMENT

If the **Lower Consloe Monitor Post(135)** is getting loosen,please tighten **Socket Head Cap Screw, M6x16mm(99)**by using **Allen Wrench(5mm)**.

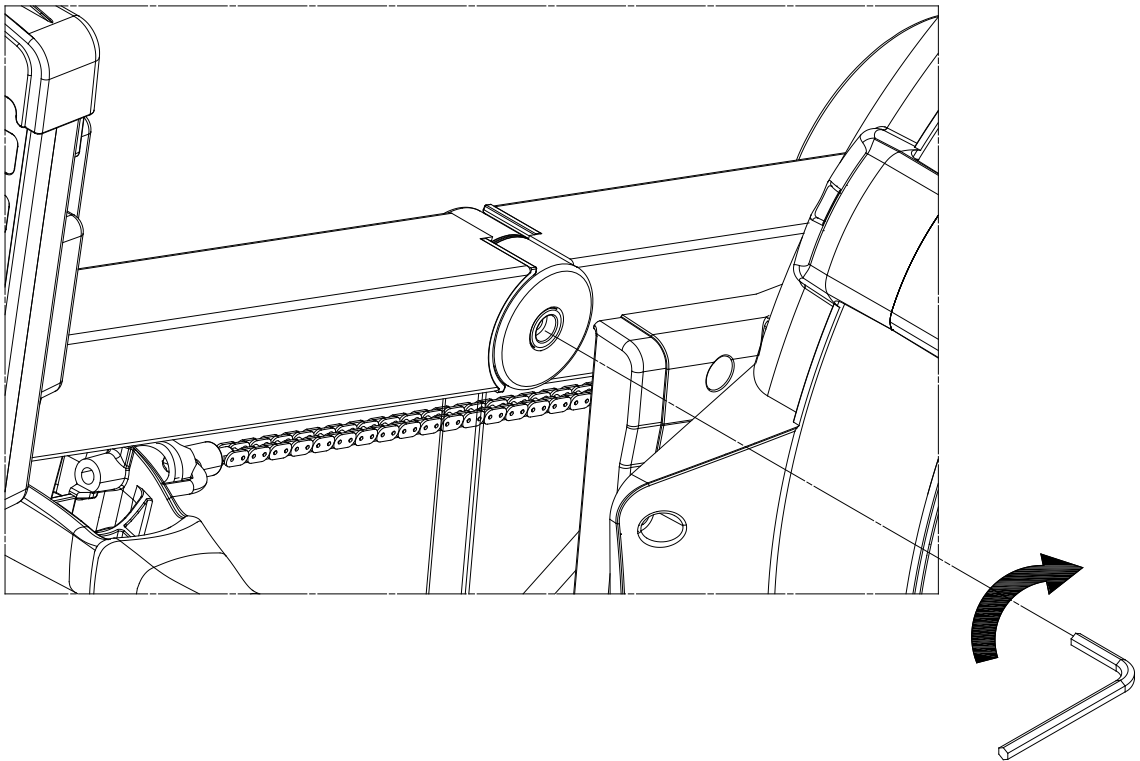

MAINTENANCE

BUNGEE CORD ADJUSTMENT

Over time, about 250,000 strokes on **Handlebar(3)**, your **Bungee Cord(38)** may stretch. Follow the following process to adjust:

1. Position the **Main Frame Assembly(175)** as shown in the illustration. Remove the **Main Frame Top Cap(68)** from the **Main Frame(175)**. Slide out the **Bottom Cover(70)** from the **Main Frame(175)**.

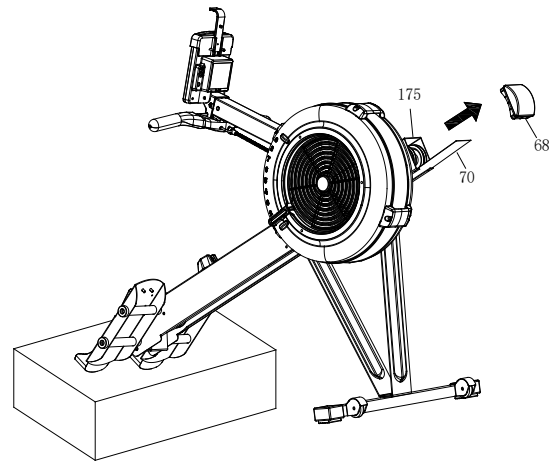

2. Position the **Main Frame Assembly(175)** as shown in the below illustration. Unhook the **Left Bungee Cord Hook(12L)** from the **Main Frame(175)**. Make a mark on the **Bungee Cord (38)** to move the hook forward 2 inches. Refer to **View 1** to **View 3** to untie the **Bungee Cord (38)** from the **Left Bungee Cord Hook(12L)**, and move the hook forward 2 inches. Refer to **View 4** to **View 6** to retie the **Bungee Cord(38)** to the **Left Bungee Cord Hook(12L)**. Hook the **Left Bungee Cord Hook(12L)** back into the **Main Frame(175)** and push the hook to the left side to touch the inner wall of the **Main Frame(175)**.

NOTE: Always use two hands with a secure grip when re-attaching the **Bungee Cord Hooks (12L & 12R)**.

Unhook the **Right Bungee Cord Hook(12R)** from the **Main Frame(175)**. Do the same as above to adjust the **Bungee Cord(38)** on the right side.

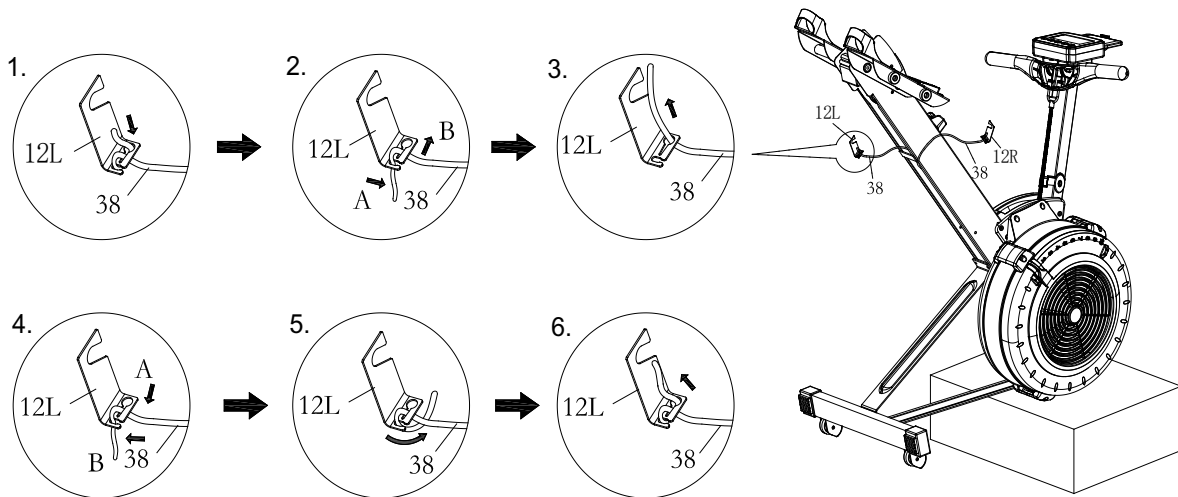

3. Position the **Main Frame Assembly(175)** as shown in the illustration. Slid the **Bottom Cover(70)** back into the **Main Frame (175)**. Press the **Main Frame Top Cap(68)** into the **Main Frame(175)**.

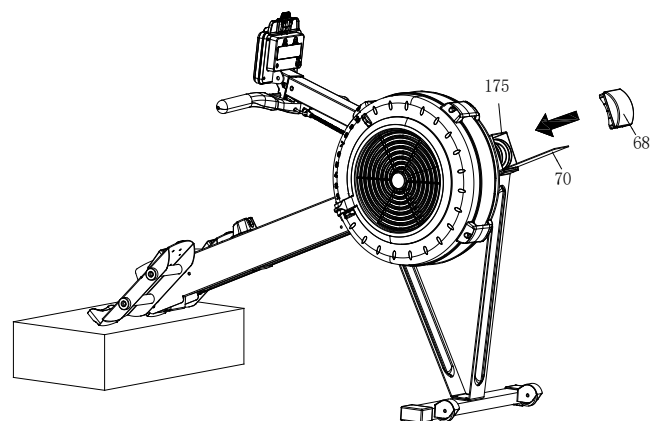

DAILY MAINTENANCE

Wipe the stainless-steel rail with a cloth or non-abrasive pad with soap or alcohol after use.

Note: Do not use bleach or acid cleaners.

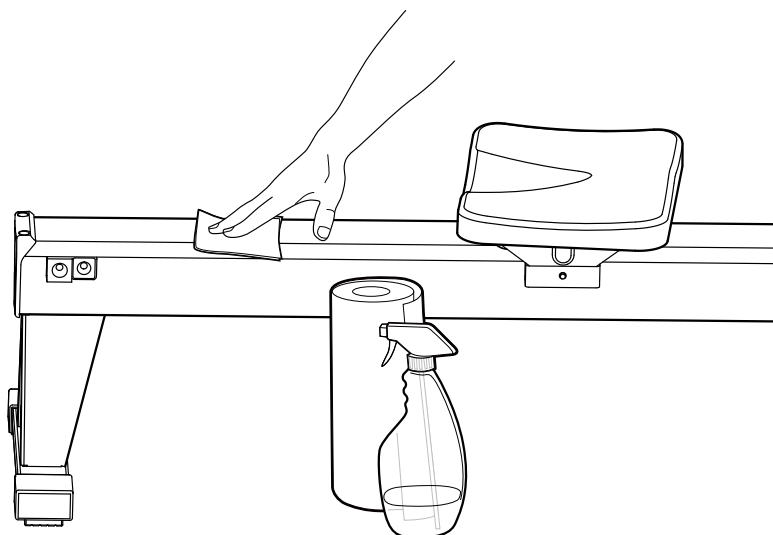

EVERY 500 HOURS OF USE (Weekly for Commercial Setting)

Lubricate the chain with a teaspoon of purified mineral oil, 20W motor oil, or 3-in-1 oil. Apply the oil on a paper towel. Rub the paper towel along the full length of the chain. Wipe off excess. Repeat if not enough.

Note: Do not clean the chain with any kind of cleaner.

EVERY 250 HOURS OF USE (Monthly for Commercial Setting)

1. Inspect the chain

Inspect the chain for stiff links. If any are found, apply thorough lubrication to resolve the issue. If unable to remedy the situation, then a new chain should be fitted.

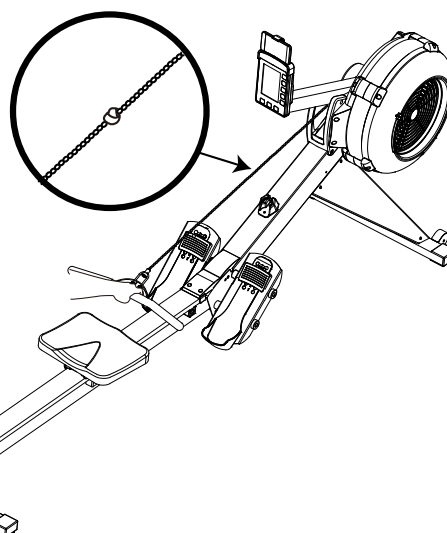

EVERY 250 HOURS OF USE (Monthly for Commercial Setting)

2. Inspect handle connection

Inspect the nuts on the U-bolt that holds the chain and handle together. Ensure that all bolts are tight and secure. Never use when loose.

See illustration below.

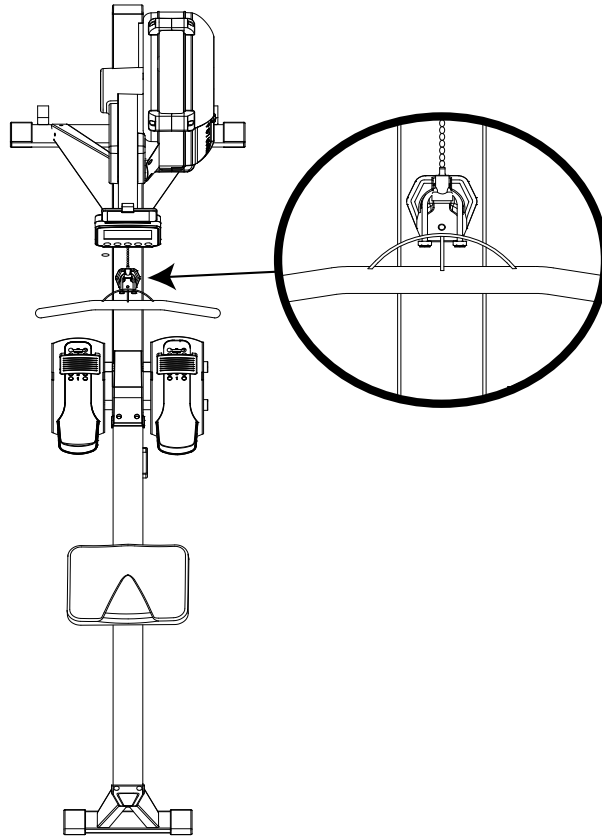

3. Inspect fasteners and fixings

Check all visible fixings on the Rower/ Monitor and tighten as required.

EVERY 250 HOURS OF USE (Monthly for Commercial Setting)

5. Clean the flywheel

Over time, dust and lint may collect inside the flywheel and on the stainless-steel mesh. This will restrict airflow and lower the resistance of the fan. It is important to keep the flywheel and mesh clean at all times. The flywheel and mesh can be cleaned by following the instructions below.

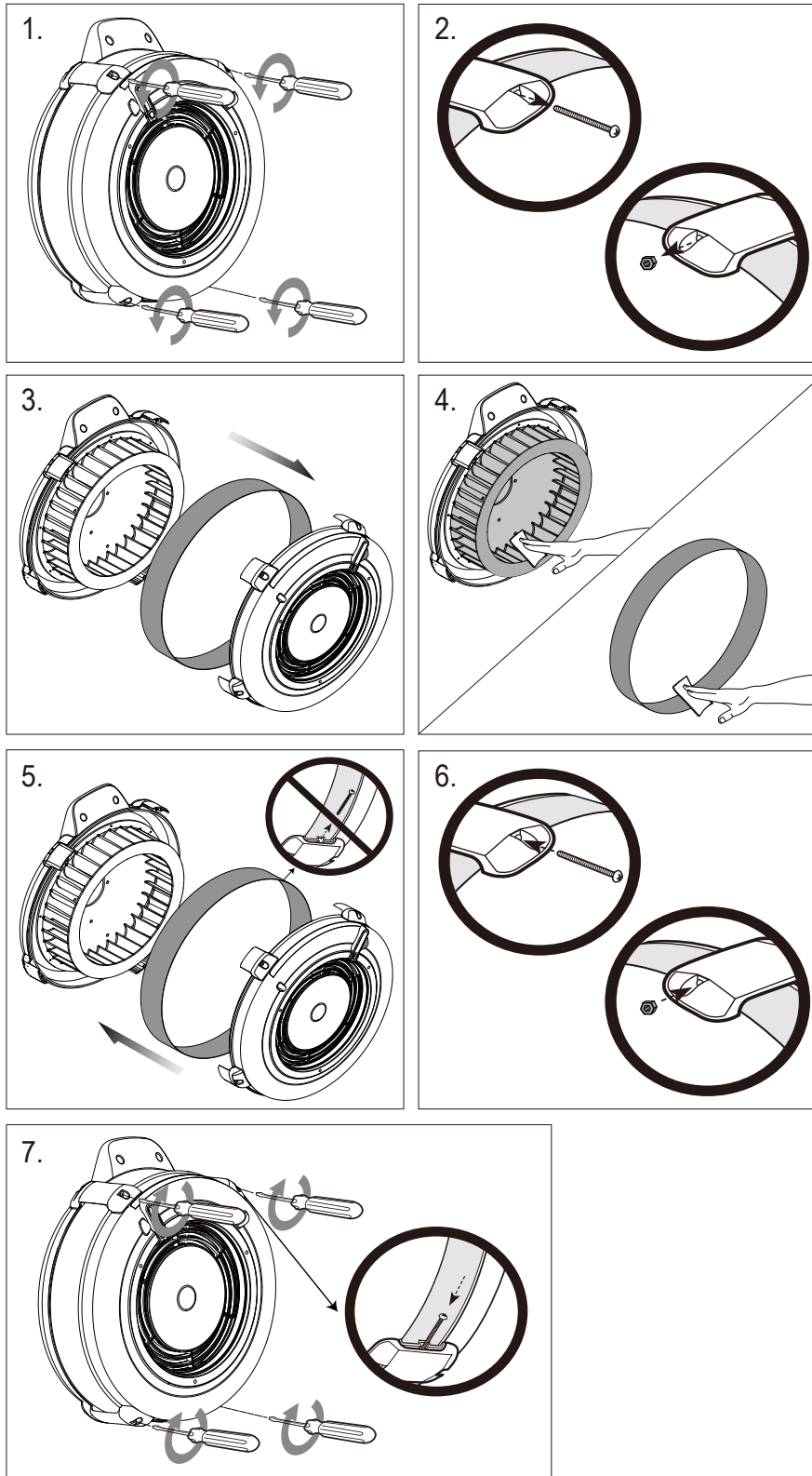

STORAGE

1. To store the **ROWER**, simply keep it in a clean dry place.
2. To avoid damage to the electronics, remove the batteries from the **Console Monitor(19)** before storing the **ROWER** for one year or more.
3. Move the **ROWER** with the **Transport Wheels(66)** on the **Front Stabilizer(4)**. Lift the Rear Stand of the **Rail Frame(176)** to move the **ROWER**. Refer to the illustration below. Do not use the **Seat(51)** to move the **ROWER**. The **Seat(51)** will move and the **Seat Carriage(10)** may pinch your hand or fingers.

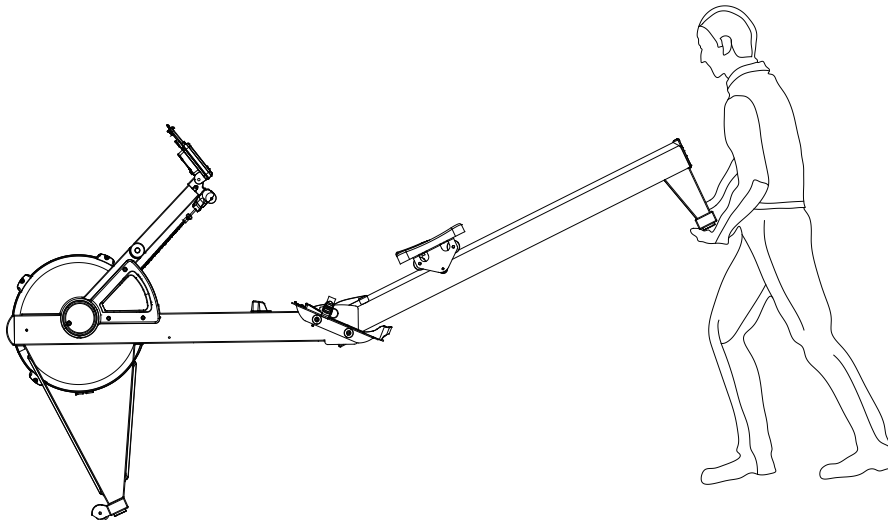

4. The **Main Frame(175)** and the **Rail Frame(176)** can be separated to minimize the unit size for storage. Remove the **Pull Pin(98)** from the **Main Frame(175)**. Lift up the **Main Frame(175)** and pull out the **Rail Frame(176)** to separate. Insert the **Pull Pin(98)** back to the hole in the **Main Frame(175)** for storage.

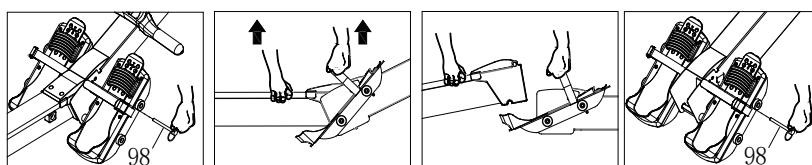
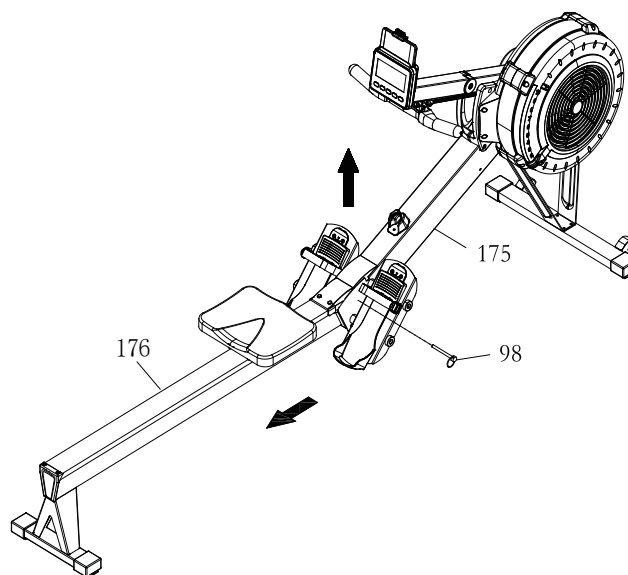

PRODUCT PARTS DRAWING

FRONT

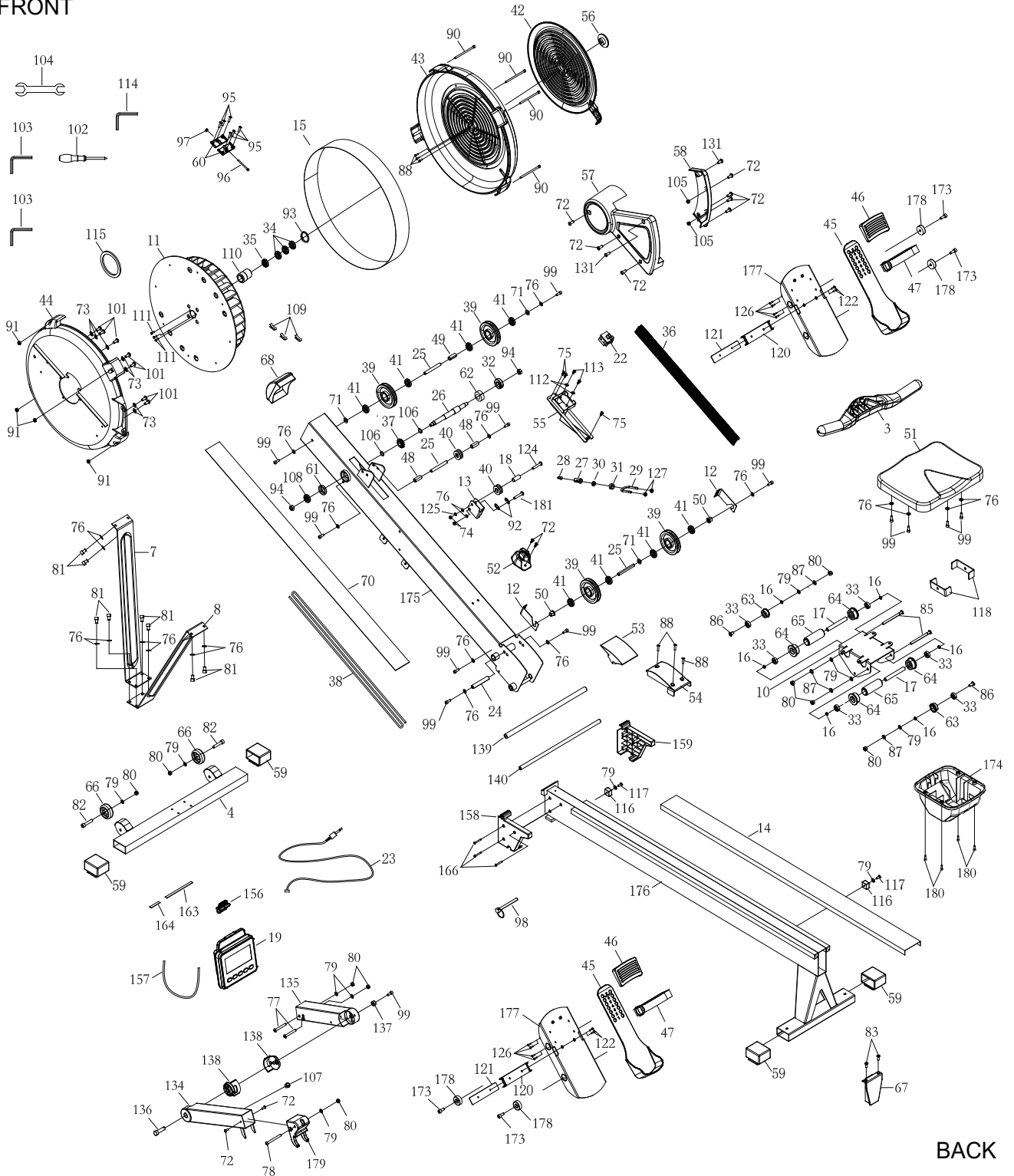

PARTS LIST

PART#	DESCRIPTION	QTY
3	Handlebar	1
4	Front Stabilizer	1
7	Front Support Leg A	1
8	Front Support Leg B	1
10	Seat Carriage	1
11	Fan	1
12	Bungee Cord Hook	2
13	Chain Bracket	1
14	Stainless Steel Rail	1
15	Perforated Steel Mesh	1
16	Spacer, $\varnothing 8.2 \times \varnothing 12 \times 3.2 \text{mm}$	6
17	Spacer, $\varnothing 8.2 \times \varnothing 12 \times 71.6 \text{mm}$	2
18	Spacer, $\varnothing 6.2 \times \varnothing 10 \times 15.5 \text{mm}$	1
19	Console Monitor	1
22	Generator	1
23	Sensor Cable	1
24	Shaft, M6x $\varnothing 12 \times 80 \text{mm}$	1
25	Shaft, M6x $\varnothing 10 \times 76.5 \text{mm}$	3
26	Fan Axle	1
27	Hook Connector	1
28	Chain Connector	1
29	U Bolt	1
30	Inner Spacer	1
31	Outer Collar	1
32	Bearing 6003RS	1
33	Bearing 608ZZ	6
34	Bearing 6201RS	3
35	One Way Bearing HF2016	1

36	Chain	1
37	Sprocket	1
38	Bungee Cord	1
39	Bungee Cord Pulley	4
40	Chain Roller	2
41	Bearing 6000ZZ	8
42	Damper	1
43	Right Fan Shroud	1
44	Left Fan Shroud	1
45	Foot Pedal	2
46	Foot Pedal Holder	2
47	Pedal Strap	2
48	Spacer, $\varnothing 10 \times \varnothing 16 \times 30.5 \text{mm}$	2
49	Pulley Spacer, $\varnothing 10 \times \varnothing 16 \times 26.5 \text{mm}$	1
50	Pulley Bushing	2
51	Seat	1
52	Handlebar Holder	1
53	Upper Joint Cover	1
54	Lower Joint Cover	1
55	Generator Base	1
56	Damper Cap	1
57	Left Side Cover	1
58	Right Side Cover	1
59	Foot Cap	4
60	Steel Plate	2
61	Bushing 6001	1
62	Bushing 6003	1
63	Guide Roller	2
64	Seat Roller	4
65	Roller Sleeve	2
66	Transport Wheel	2
67	Rail End Cap	1

68	Main Frame Top Cap	1
70	Bottom Cover	1
71	Plastic Washer, $\varnothing 10.2 \times \varnothing 14 \times 1 \text{mm}$	3
72	Phillips Pan Head Screw, M6 x10mm	11
73	Lock Washer, Internal Tooth M6	7
74	Nylon Lock Nut, M6	2
75	Phillips Pan Head Self-Tapping Screw, ST4.2x10mm	3
76	Flat Washer, M6	22
77	Socket Head Cap Screw, M8x65mm	2
78	Button Head Cap Screw, M8x75mm	1
79	Flat Washer, M8	11
80	Nylon Lock Nut, M8	9
81	Socket Head Cap Screw, M6x16mm	8
82	Socket Head Cap Screw, M8x40mm	2
83	Phillips Flat Head Screw, M6x16mm	2
85	Socket Head Cap Screw, M8x110mm	2
86	Button Head Cap Screw, M8x25mm	2
87	Lock Washer, M8	4
88	Phillips Pan Head Self-Tapping Screw, ST4.2x16mm	6
90	Socket Head Cap Screw, M5x92mm	4
91	Hex Nut, M5	4
92	Chain Hook	2
93	Elastic Ring	1
94	Nylon Lock Nut, M10	2
95	Phillips Pan Head Self-Tapping Screw, ST4.2x6mm	6
96	Phillips Pan Head Screw, M4x45mm	1
97	Hex Nut, M4	1
98	Pull Pin	1
99	Socket Head Cap Screw, M6x16mm	13
101	Phillips Truss Head Screw, M6x10mm	7
102	Screwdriver	1
103	Allen Wrench, 6mm	2

103	Allen Wrench, 6mm	2
104	Wrench	1
105	Hex Nut, M6	2
106	PU Spacer	2
107	Plug	1
108	Bearing, 6001RS	1
109	Balance Weight	3
110	Bearing Bushing	1
111	Socket Head Cap Screw, M4x12mm	3
112	Washer, $\varnothing 12 \times \varnothing 3.5 \times 1$ mm	2
113	Phillips Pan Head Self-Tapping Screw, ST3.5x12mm	2
114	Allen Wrench, 5mm	1
115	Magnet	1
116	Stopper Bumper	2
117	Button Head Cap Screw, M8x20mm	2
118	Stopper Bracket	2
120	Pedal Strap Stopper Plate	2
121	Pedal Strap Protector	2
122	Phillips Flat Head Screw, M5x12mm	4
124	Phillips Truss Head Screw, M6x30(Half Thread)	1
125	Lock Washer M6	1
126	Phillips Pan Head Self-Tapping Screw, ST4.2x10mm	8
127	Nylon Lock Nut M6	2
131	Phillips Pan Head Screw, M6x12mm	2
134	Upper Console Monitor Post	1
135	Lower Console Monitor Post	1
136	Screw Shaft	1
137	Small Pulley Bushing	1
138	Rotation Sleeve	2
139	Pedal Shaft, 16mm	1
140	Pedal Shaft, 12mm	1

156	Smartphone Holder	1
157	Bungee Cord of Smartphone Holder	1
158	Left Joint Cover	1
159	Right Joint Cover	1
163	Console EVA Pad	1
164	Smart Phone Holder EVA Pad	1
166	Phillips Pan Head Self-Tapping Screw, ST4.2x35mm	3
173	Socket Head Cap Screw, M8x20mm	4
174	Seat Carriage Cover	1
175	Main Frame	1
176	Rail Frame	1
177	Pedal Support Plate	2
178	Foot Pedal End Cap	4
179	Console Mounting Bracket	1
180	Socket Head Cap Screw, M5x16	4
181	Phillips Truss Head Screw, M6x28	1