



HIT FITNESS

HIT00707



USERE MANUAL- Tyr Multi-Gym

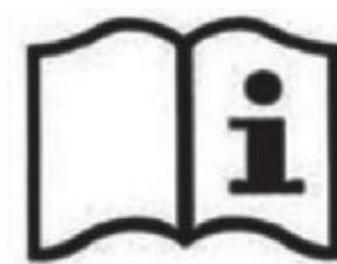

Precautions for use











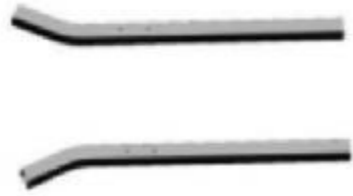



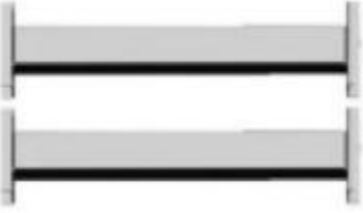

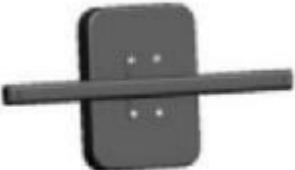





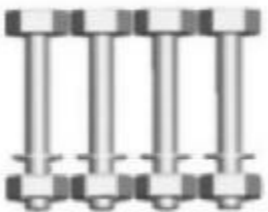

1. Please read this instruction carefully before using and installing the product.
2. Please consult your doctor before use this product correctly. If you have abnormal discomfort such as dizziness, chest tightness, physical discomfort and abnormal pain during exercise, please stop using it immediately.
immediately. This product should be used carefully for the old and the weak with hypertension, diabetes, heart disease and other diseases. Do not use this product if you suffer from otitis media, spondylitis or pleurisy (but not limited).
3. This product and all its parts may contain parts that can cause suffocation.
Please keep this product and all its parts out of the reach of children.
4. The product must be inspected before use. Do not use the product if there is any damage or missing parts.
5. This product is for home use only and should not be used for commercial purposes.
6. When using this product, keep fingers, loose clothes and hair away from moving parts.
Long hair must be tied up and all accessories like jewelry shall be taken off.
7. Please use this product properly within your own physical capacity. Please do not overuse
8. Please use this product on an absolutely smooth ground with no obstacles. It is strictly forbidden to use it on slopes or slippery floors.
9. Please do not exercise within 40 minutes after a meal.
10. Please ensure that the distance between the equipment and the obstacles is not less than 40 inches.
11. Minors should use this equipment under the supervision of an adult and strictly follow the instructions for use.
12. Only with proper equipment installation, maintenance and use can achieve safe and effective training. Users must be familiar with all warnings and precautions of the equipment.

Storage and maintenance

1. Store the product in a cool place. Do not expose it to the sun for a long time.
2. Wipe the surface of the fuselage regularly with wet cloth.
Do not use corrosive substances for cleaning.
3. Do not place heavy objects on the product.

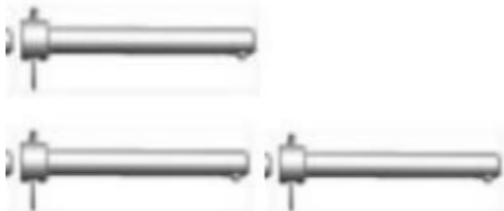
Step 1:

Check and confirm all the parts below are included.

<p>① Foot tubes (1 pair)</p> 	<p>② Main frame+handle (2 pairs)</p> 	<p>③ Upper arms (1 pair)</p> 	<p>④ Elbow cushions (1 pair)+ Elbow cushion screws</p> 
<p>⑤ Bottom foot sleeves (2 pairs)</p> 	<p>⑥ Foot tube connect pipes (front and rear)</p> 	<p>⑦ Horizontal bar</p> 	<p>⑧ Connect pipes of the main frame (1pair)</p> 
<p>⑨ Back cushion</p> 	<p>⑩ Supporting tubes</p> 	<p>⑪ Sit-up bench</p> 	<p>⑫ Feet rest tube (1) Connecting pipe rubber cotton pull rope (2pcs)</p> 
<p>Kit Accessories</p>			
<p>External hexagon screws a. M8x90mm(4 pcs)</p> 	<p>Carriage Bolts b. M8×65mm(16 pcs)</p> 	<p>External hexagon screws c. M8x45mm(4 pcs)</p> 	<p>Plastic handle screws d. M8x40(2pcs)</p> 
<p>External hexagon screws e. M8x12mm(2 pcs)</p> 	<p>Plastic handle nuts f. M8x12mm(2 pcs)</p> 	<p>g. Fix plates (2 pcs)</p> 	<p>h. Half round head screws M6*60mm (4 pcs)</p> 
<p>External six angle wrenches (2pcs) i. Cross screwdriver (1pcs)</p> 	<p>External hexagon screws j. M8x55mm(2 pcs)</p> 	<p>k. Bolt 8mmx66mm(3pcs)</p> 	<p>l. External hexagon screws M8*55mm (1 pcs)</p> 
<p>n. Carriage Bolts M10*80mm + Plastic screw nut (1 set)</p> 	<p>m. outer hexagon screws M8x75mm (4 pcs)</p> 	<p>o. Half round head screws M8*30mm (4 pcs)</p> 	

Step 2:

Install 4 foot sleeves

- ① Put foot tubes into the 4 bottom foot sleeves respectively (4 foot set parallel to the ground)



Step 3:

Mount the foot tube connecting pipes to connect left and right main frame

- ① Fasten the connect rods with the 8pcs Carriage Bolts (b. M8×65mm).



Step 4:

Install the main frame

- ① Fix the bottom of the main frame and supporting tubes with the 8pcs Carriage Bolts (b. M8X65mm).
- ② Attach the main frame tubes with the curved fix plates and fasten it with the (a. M8x90mm) external



As shown in the picture



Step 5:

Install the top connecting rod

- ① Use the external hexagon (c. M8x45mm) screws to pass out from the inside, put the fixed plate on, and fasten it with the nuts of M8.



Step 6 :

Install the elbow cushion

Tighten the plates with the built-in screws (h. Half round head screws M6*60mm) of elbow cushions. And tighten the L shape handle too with screws (0. Half round head screws M8*30mm (4 pcs)).

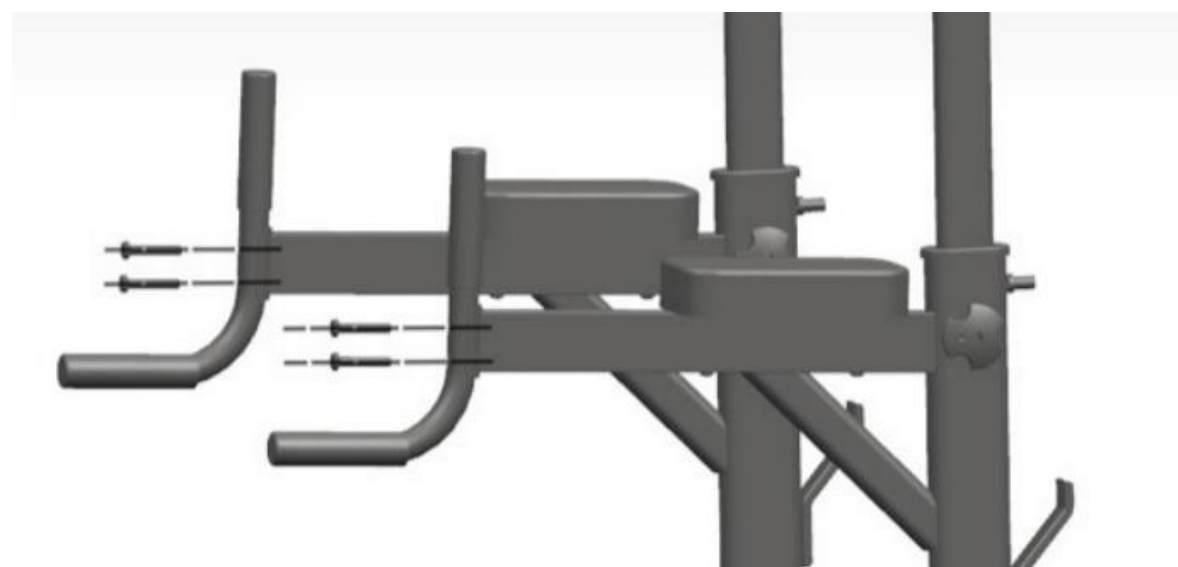
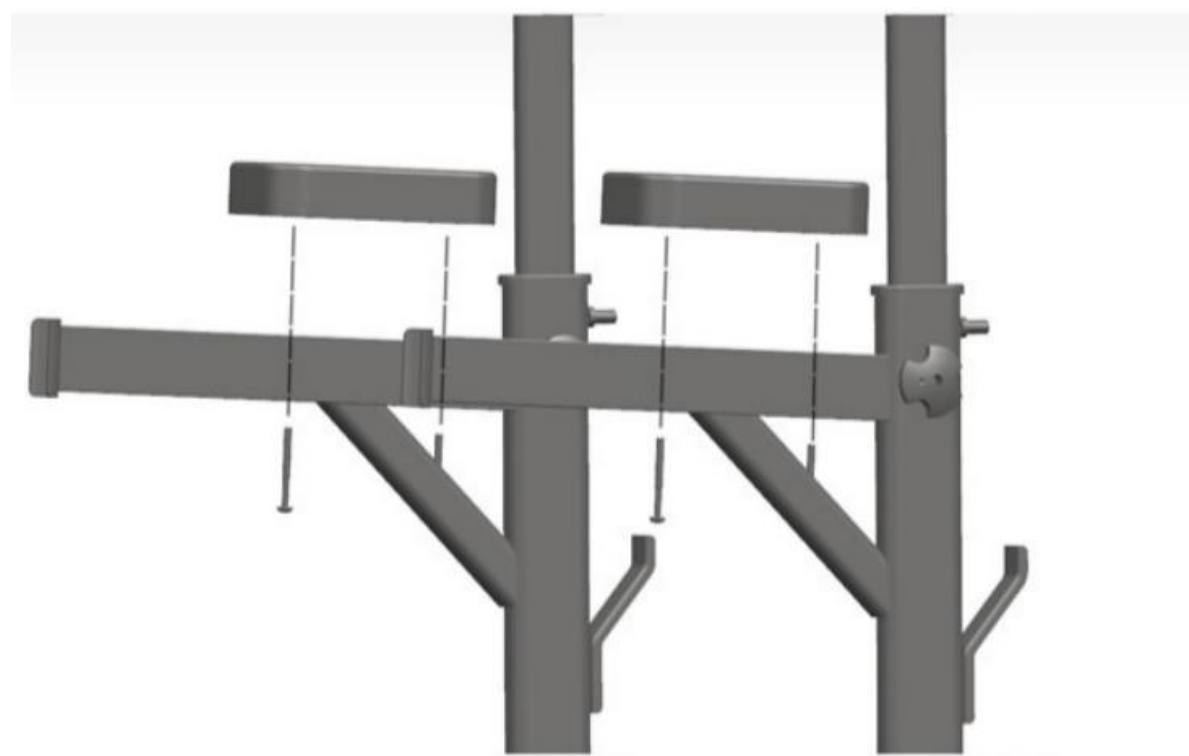

Step 7 :

Install back cushion

- ① Fasten the holes on the two ends of the back cushion to the aligned nails on the main frame with the external hexagon screws (e.M8x12mm).



Step 8:

Install upper arms and horizontal bar

- ① Insert the upper arms into the top of the main frame directly, as shown in the figure.
- ② After inserting 2 upper arms, slide down to a height that is convenient for you to install the horizontal bar at the top, as shown in the figure.
- ③ After installing the arms, put the horizontal bar on the upper arms, Align hole positions, insert the two (a.M8 x 75mm) screws from the top, fasten it with the nuts.



Step 9:

Adjust the suitable angle and height

① When adjusting the hole position to the suitable height, you can use the screw of the plastic handle screws (d.M8x40) to pass through the main frame and lock with the upper arm.

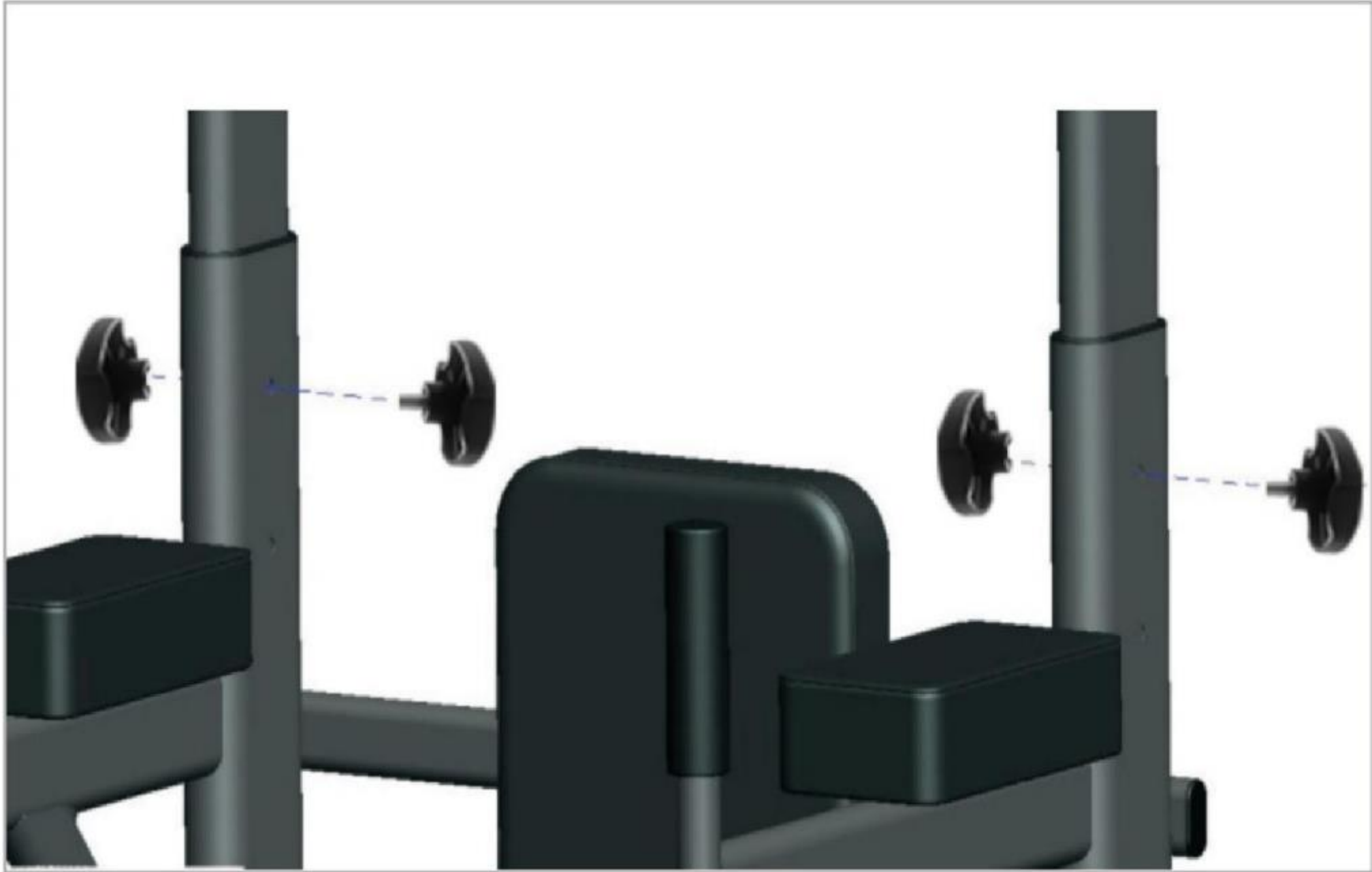

Step 10:

Install the sit-up bench

① Put the sit-up bench part on the main frame connection and use m.M8*75mm outer hexagon screws to fix it. Then insert the M8*66 bolts to a suitable hole which suits you. (will bring different angles and positions using).

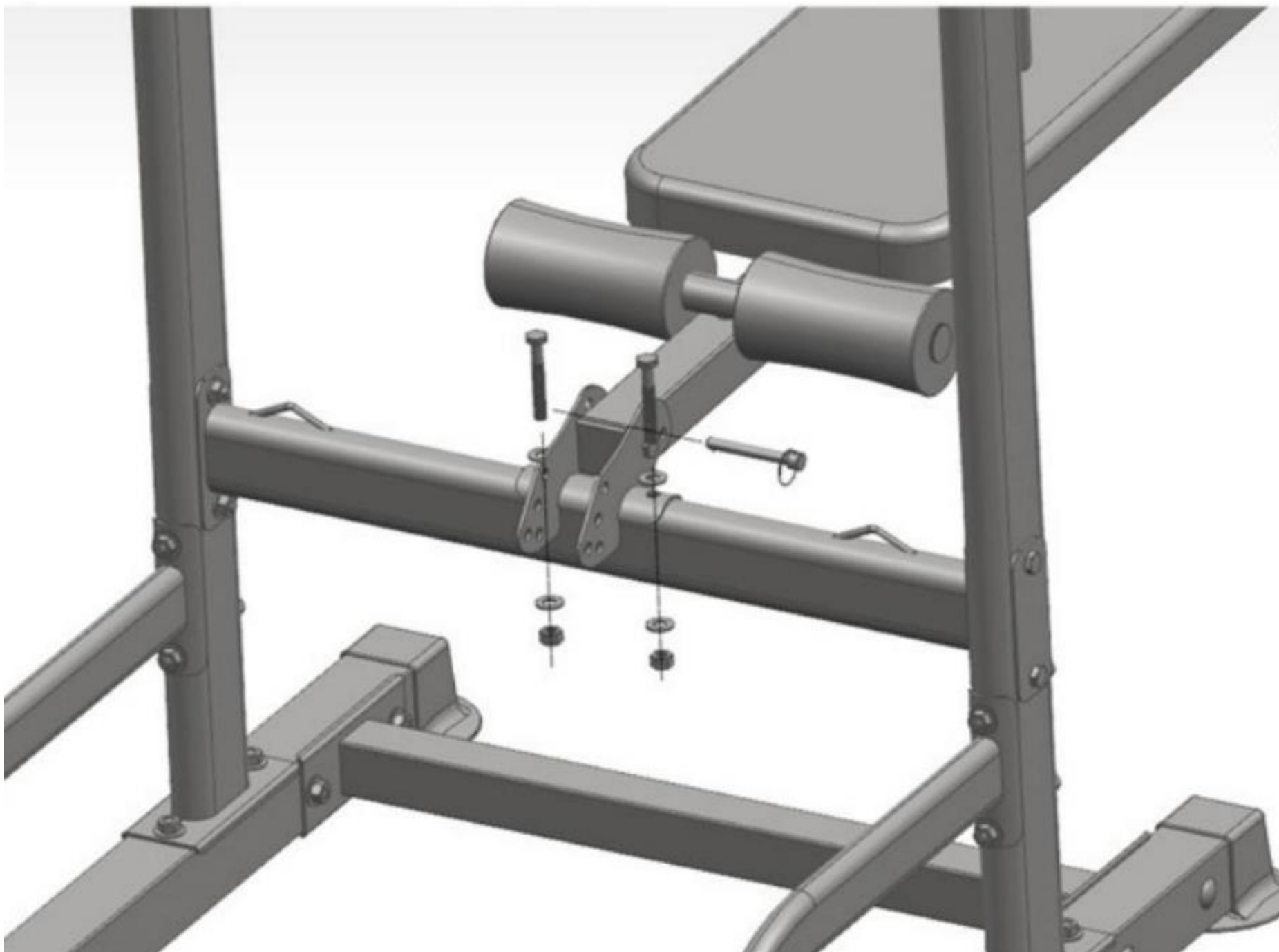

LAST Step 11:

Install the foot rest

① Rotate the M8*55mm outer hexagonal screw to fix the foot rest, adjust the foot rest to a suitable position, and insert the 8*66 bolt.

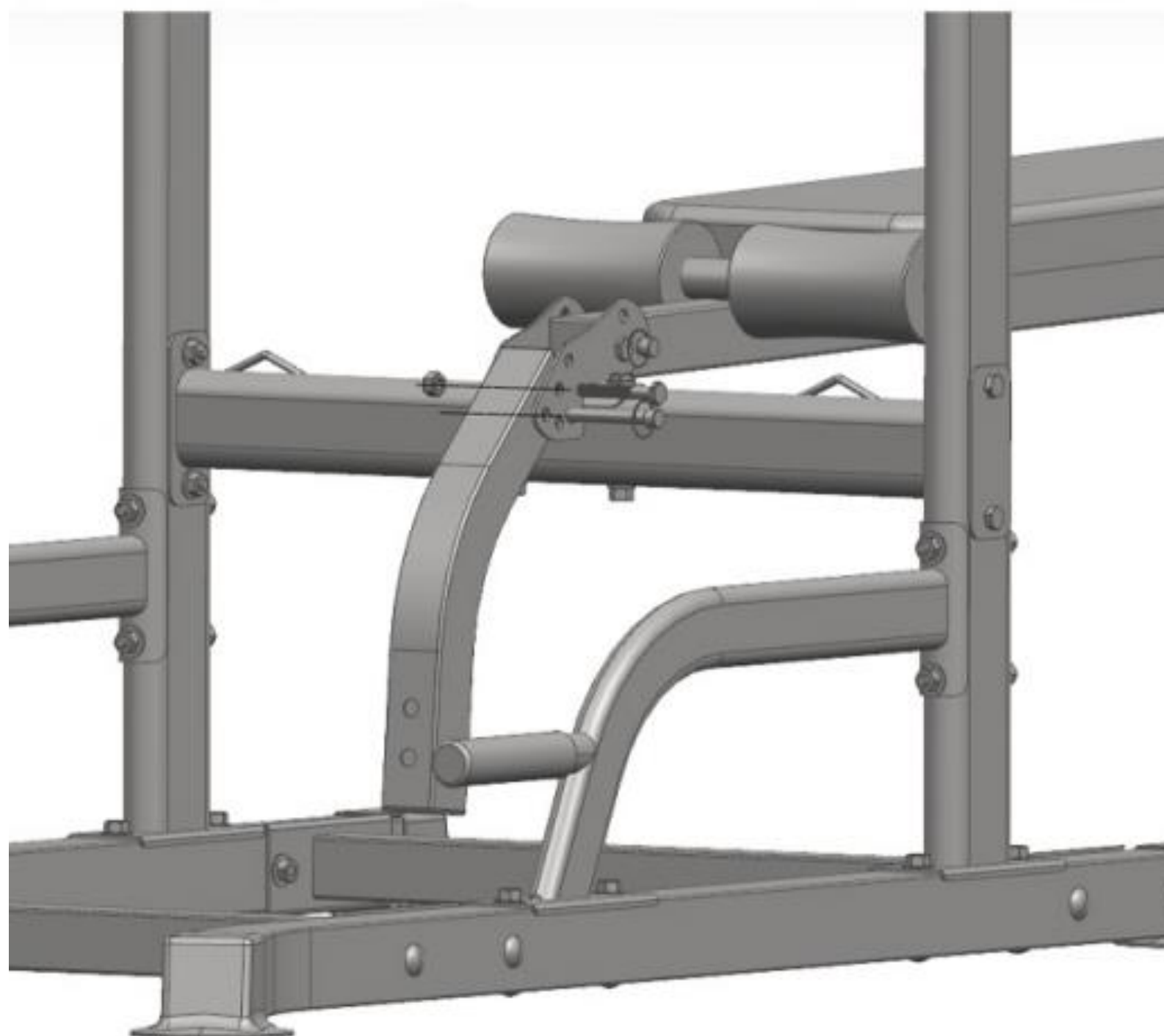

② Insert carriage screw M10*80mm into the mounting hole as shown in the picture, and then use the plastic cover of the M10 to rotate and secure.

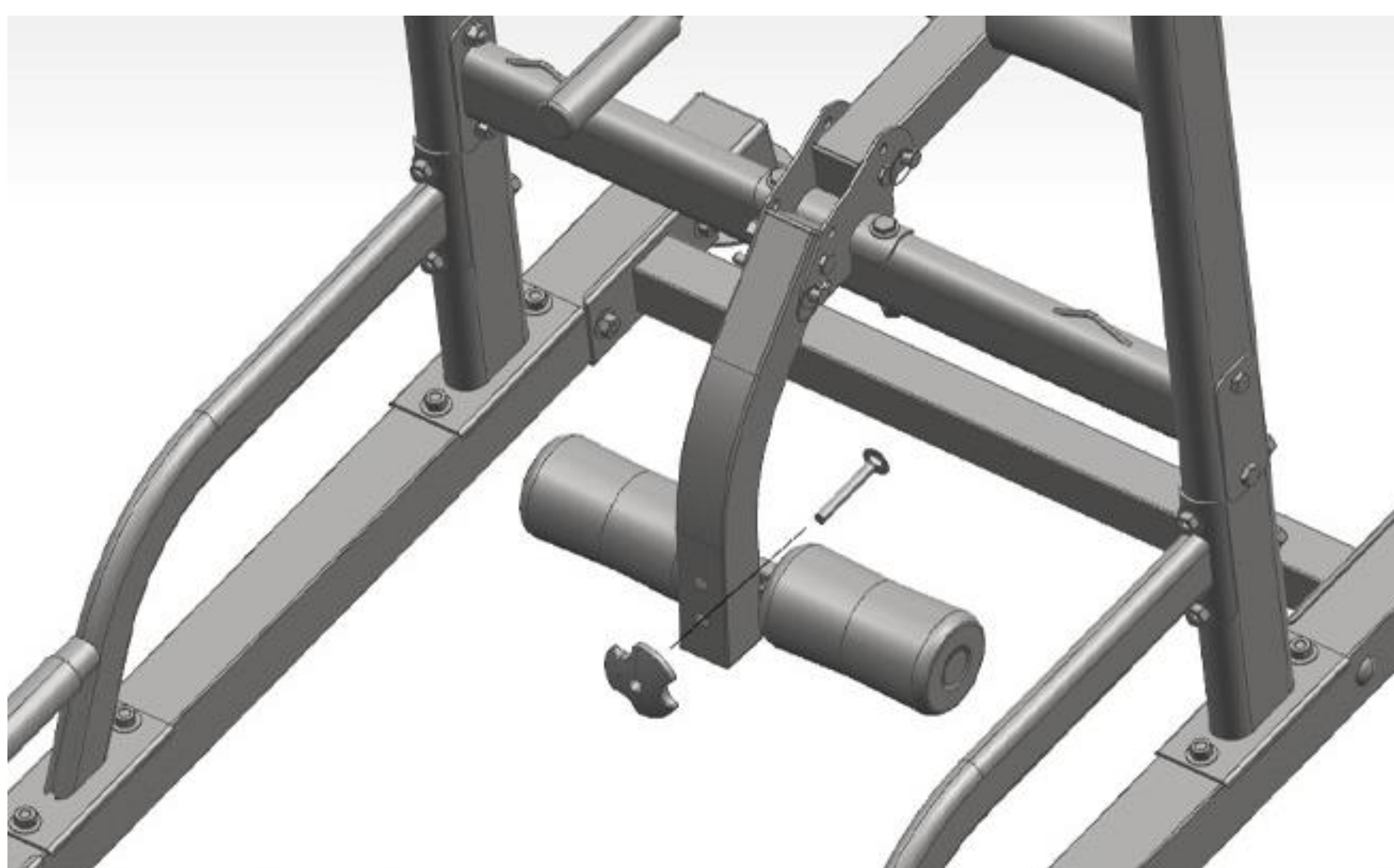

Installation complete as shown

