





HIT FITNESS

HIT00778

Hit Fitness F200 / Half Rack Wrist Roller Attch

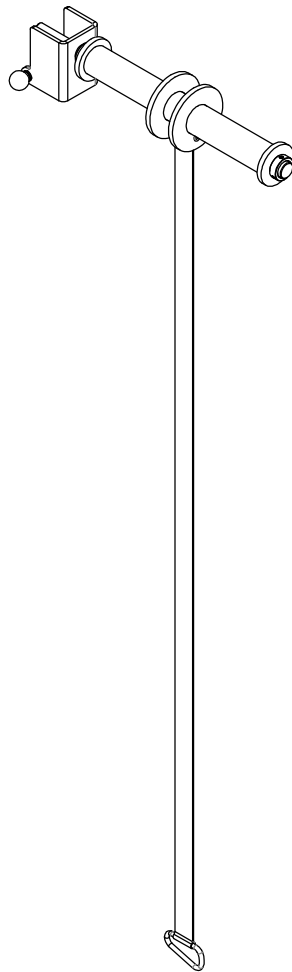
Assembly Manual

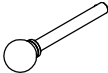

① $\Phi 10$ pin  × 1	② fixing ring  × 2
--	--

1

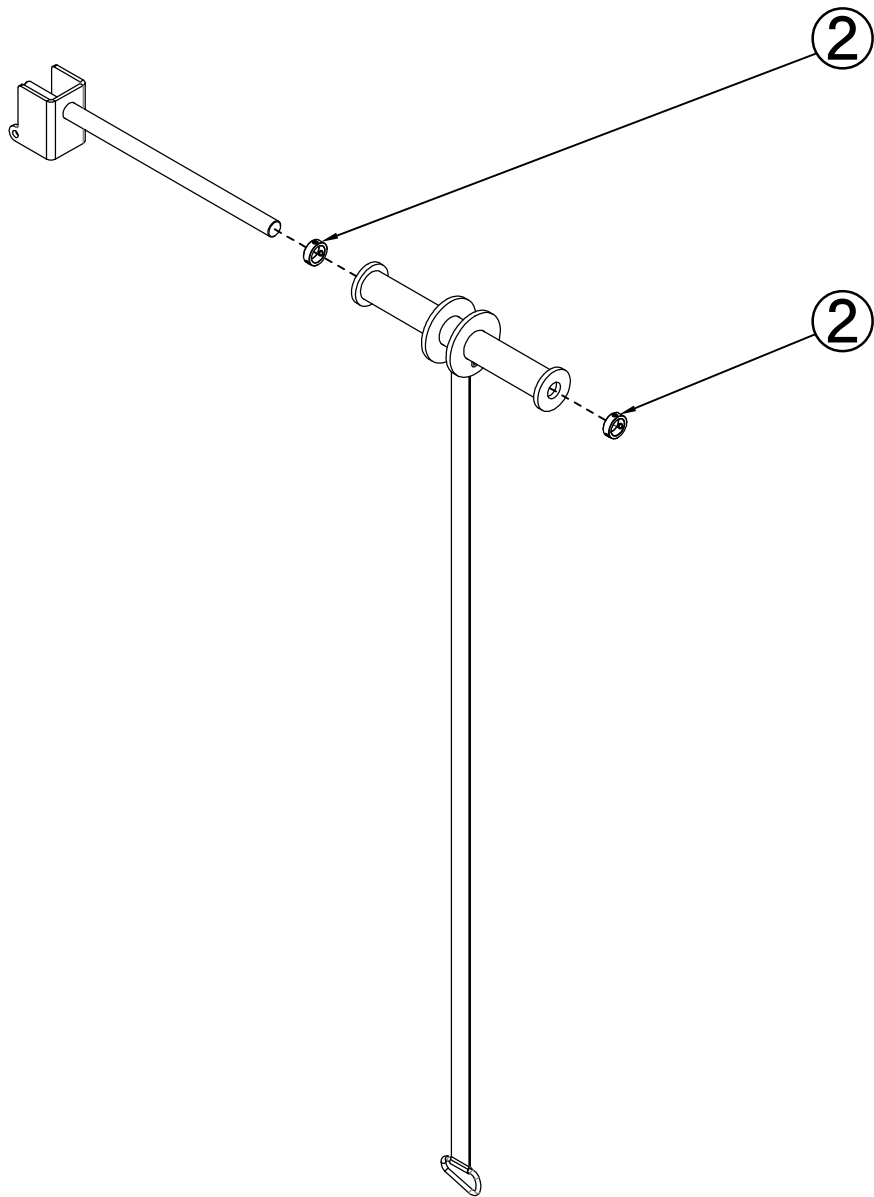

(1)

2

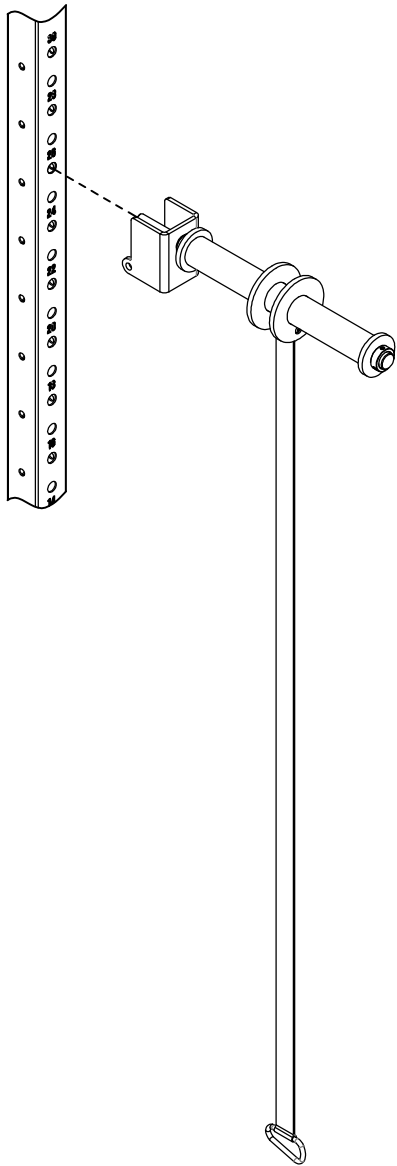

3

