

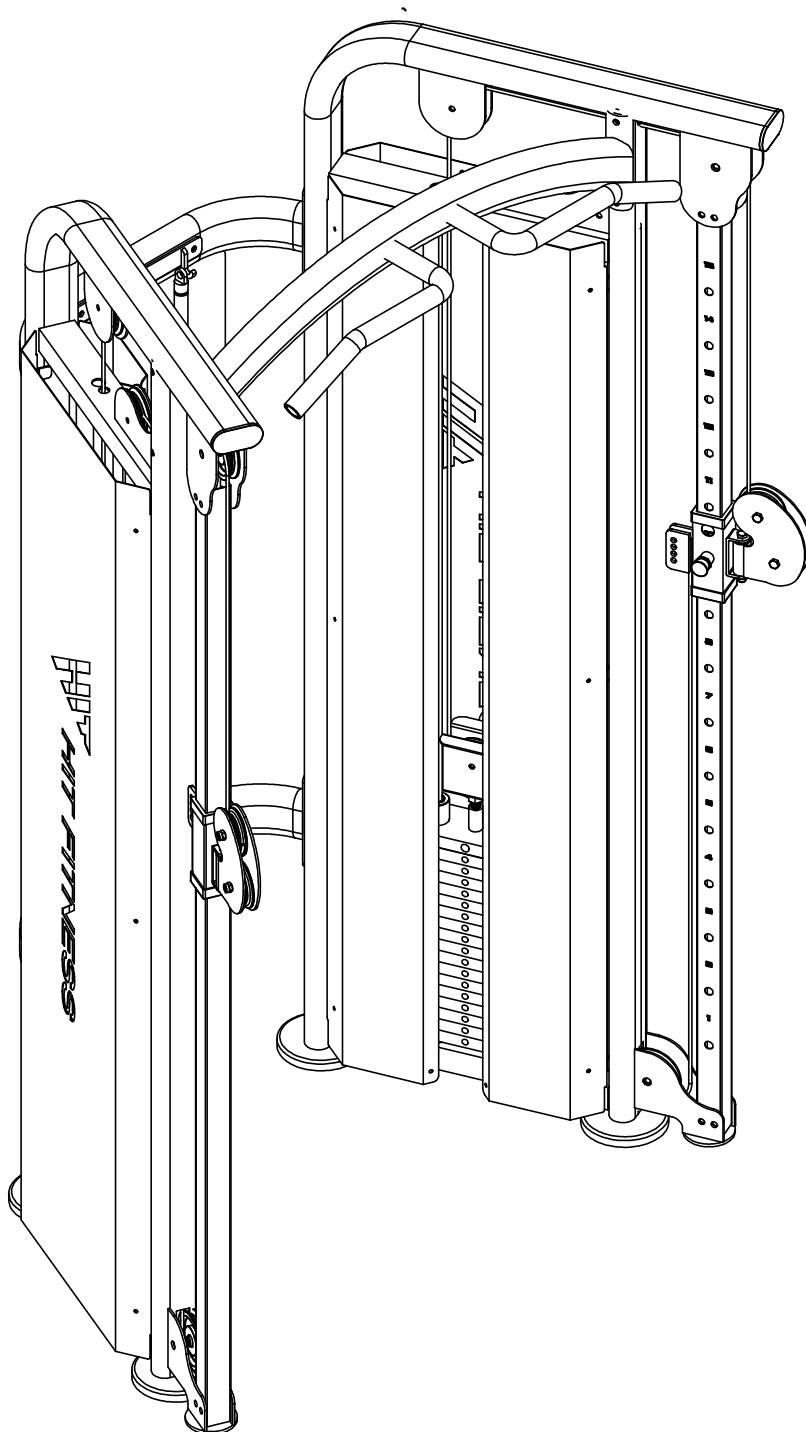

**HIT FITNESS**

**Hit Fitness Comm Stealth Functional Trainer**

**HIT00750**



# EXPLORE DRAWING

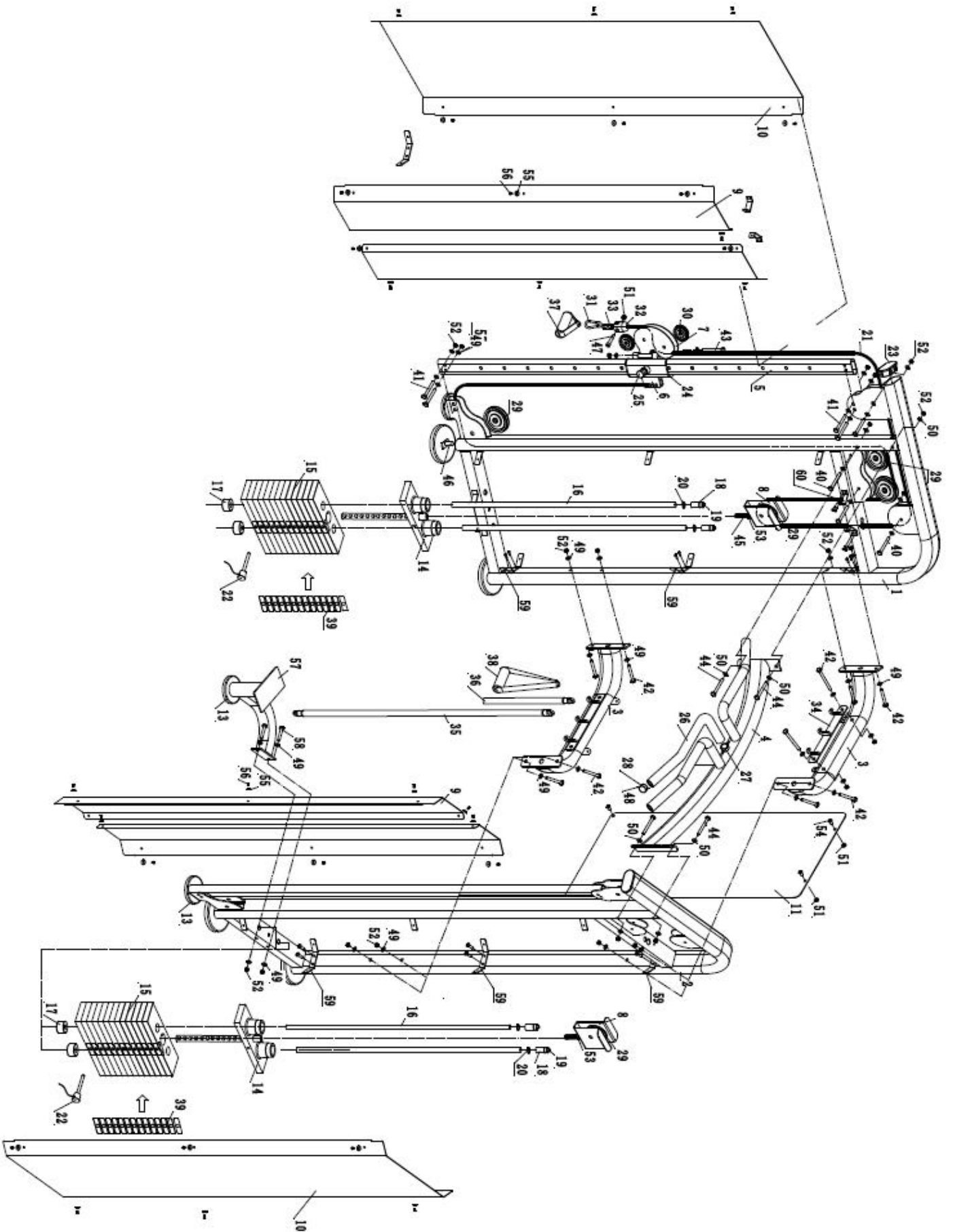

## PART LIST

PART NO	PART NAME	Q'TY
1	Left main frame	1
2	Right main frame	1
3	Rear connect support	2
4	Up support frame	1
5	Adjustable fixed tube	2
6	Adjustable moving frame	2
7	Moving wheel frame	2
8	Moving pulley frame	2
9	Front cover	2
10	Rear cover	2
11	Middle cover	1
12	Ground plate	4
13	Round cushion	3
14	Top plate	2
15	Weight stack plate	38
16	Guide rod	4
17	Damping block	4
18	Fixed sleeve of guide rod	4
19	M10*20mm Allen head fasten screw	4
20	Shaft circlips	4
21	Steel wire rope	2
22	Strong magnetic latch	2
23	Flat oval plug	2
24	Adjust bush	4
25	Pull pin assembly	2
26	Dipping plastic handlebar	2
27	Aluminum gear sleeve	2
28	Aluminum cover	2
29	Big pulley	12
30	Small pulley	4
31	Hoist hook	2
32	Steel wire rope cover	2
33	Steel wire rope fixed sleeve	2
34	Hook frame	2
35	Long hang rod	1
36	Short hang rod	1
37	Short drawstring	2
38	Long drawstring	2
39	Weight stack label	2
40	M10*50mm bolt	12

41	M10*55mm bolt	12
42	M10*70mm bolt	12
43	M10*100mm bolt	2
44	M10*120mm bolt	4
45	M16*90mm bolt	2
46	M16*40mm bolt	4
47	M8 Plug bolt	2
48	M4*3 Fasten bolt	8
49	Ø10 Washer	84
50	Ø10 Arc Washer	8
51	M8 Nylon nut	10
52	M10 Nylon nut	44
53	M16 Nylon nut	4
54	M8*15mm bolt	4
55	Plastic washer	32
56	M5*15mm bolt	32
57	Foot frame	1
58	M10*90mm bolt	2
59	Cover support frame	12
60	Cover up support frame	8
61	4.8*16 Big cross head screw	40
Note: Some parts in above list have been assembled in advance.		

### HARDWARE LIST 1

PART NO	PART NAME	Q'TY
44	M10*120mm bolt	4
42	M10*70mm bolt	8
56	M5*15mm bolt	32
58	M10*90mm bolt	2
54	M8*15mm bolt	4
49	Ø10 Washer	20
50	Ø10 Arc Washer	8
55	Plastic washer	32
51	M8 Nylon nut	4
52	M10 Nylon nut	14
61	4.8*16 Big cross head screw	32

## HARDWARE LIST 2

PART NO	PART NAME	Q'TY
22	Strong magnetic latch	2
17	Damping block	4
18	Fixed sleeve of guide rod	4
20	Shaft circlips	4
19	M10*20mm Allen head bolt	4
T1	5# Allen Wrench	1
T2	Screw driver	1









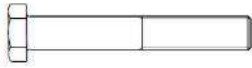

Note: Part of bolts in hardware list have been assembled in advance, please disassembled them before assembly.

## ACCESSORY LIST

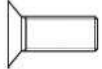
PART NO	PART NAME	Q'TY
	Short drawstring	2
	Long drawstring	2
	Bar with handle	1
	Curl bar	1
	Triceps pull rope	1
	Handlebar sleeve	1
	Gantry handlebar	2

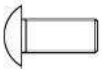
Note: Part of bolts in hardware list have been assembled in advance, please disassembled them before assembly.

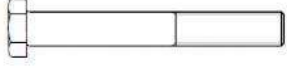
## TOOL KITS 1

44 (4PCS)			49 (20PCS)
42 (8PCS)			51 (4PCS)
56 (32PCS)			52 (14PCS)
54 (4PCS)			50 (8PCS)
58 (2PCS)			55 (32PCS)
61 (40PCS)			

TOOL KITS 2

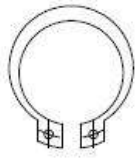

20 (4PCS)



19 (4PCS)



18 (4PCS)

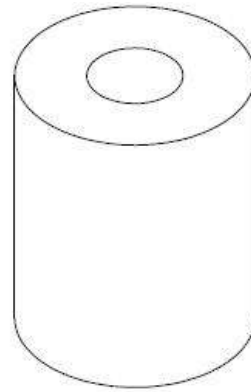

17 (4PCS)

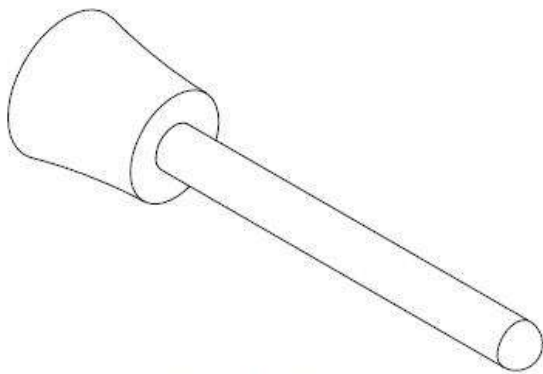

22 (2PCS)



T1 (1PC)

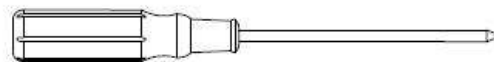

T2 (1PC)

ACCESSORIES

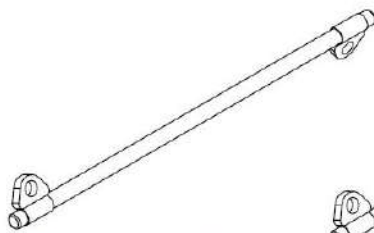

Double lug straight bar 1pc

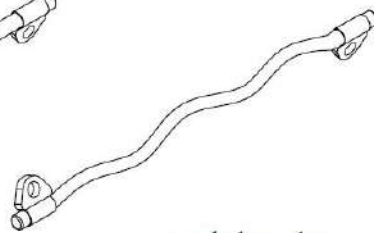

curved bar 1pc



Triceps tension rope 1pc

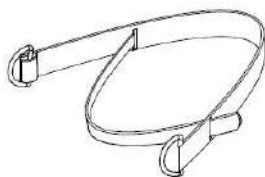

Handle sleeve 1pc



Gantry handle 2pcs



Long braided handle 2pcs



Short braided handle 2pcs

## ASSEMBLING INSTRUCTIONS

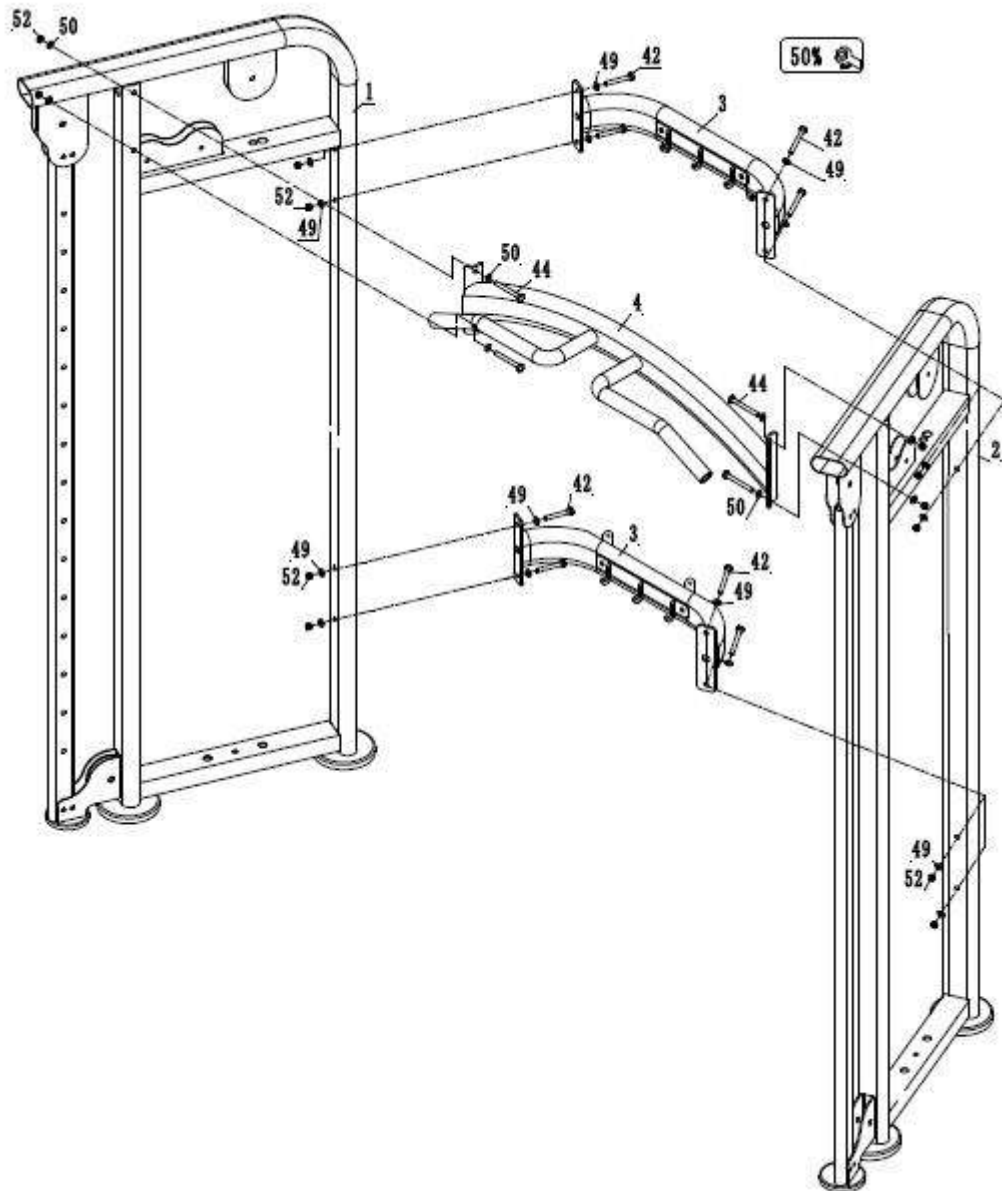

### STEP 1:

1. Fix Rear connect support 3 to Left main frame 1 and Right main frame 2 with M10\*70mm bolt 42, M8 Nylon nut 52 and Ø10 Washer 49.
2. Fix Up support frame 4 to Left main frame 1 and Right main frame 2 with M10\*120mm bolt 44, M8 Nylon nut 52 and Ø10 Arc Washer 50.

100%

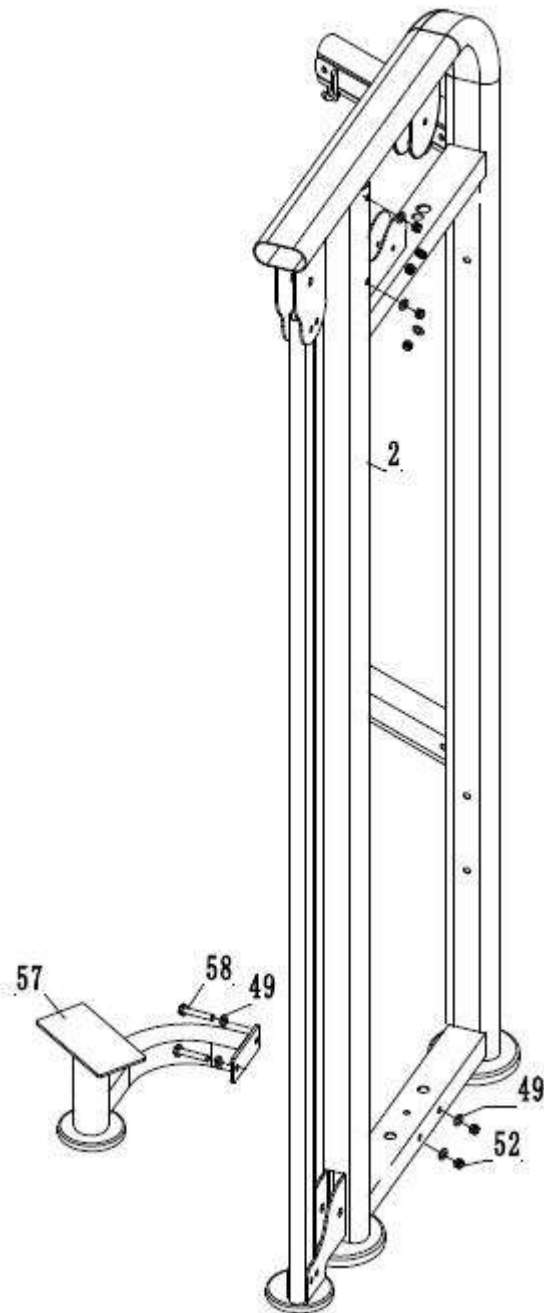

**STEP 2:**

Fix Ground frame 57 to Right main frame2 with M10\*90mm bolt58 and Ø10 Washer 49, M10 Nylon nut 52.





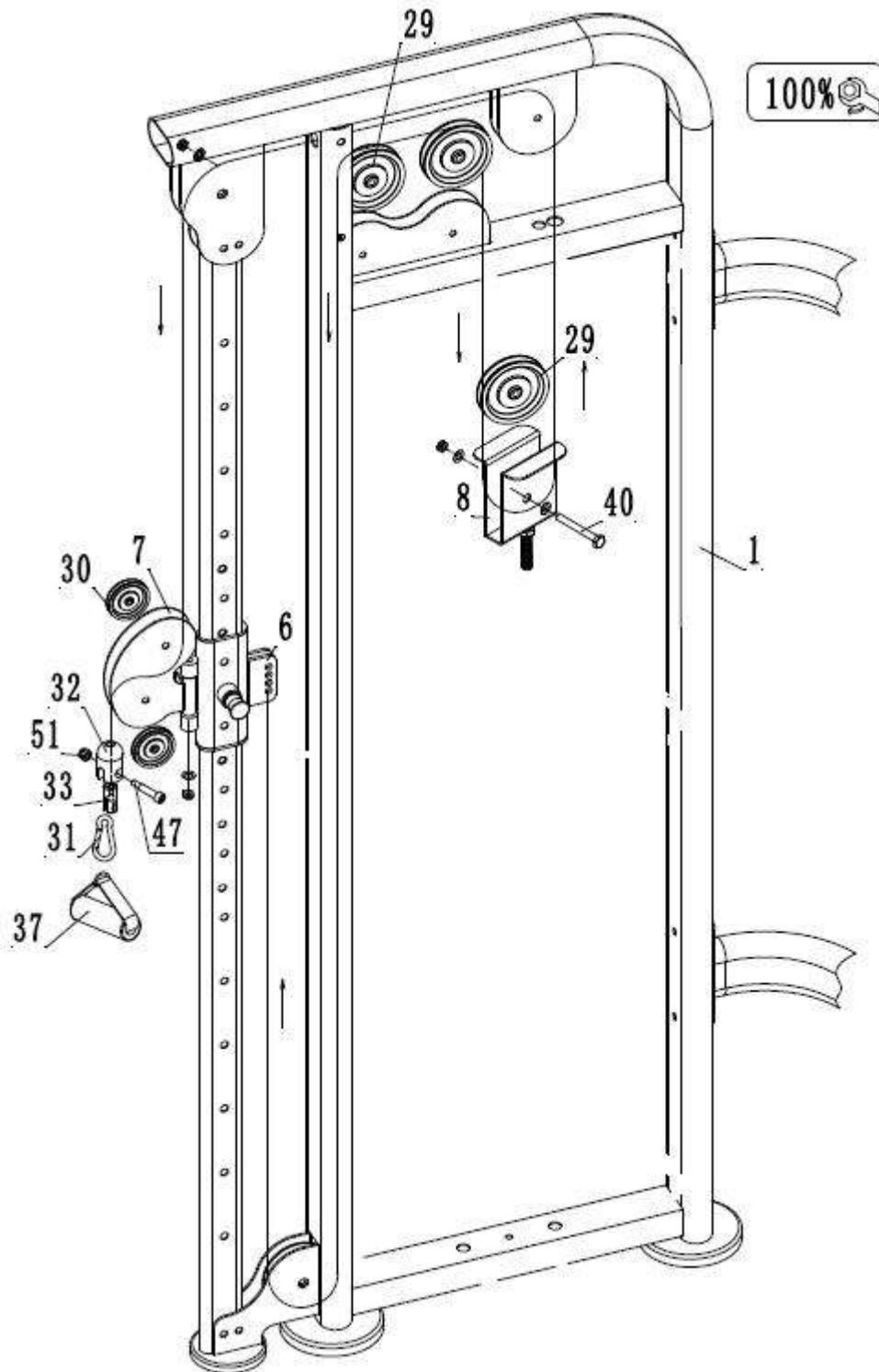

**STEP 4:**

1. Rope 21 goes as shown above.
2. Fix Steel wire rope cover 32 and Steel wire rope fixed sleeve 33 to Rope 21.
3. Fix Steel wire rope cover 32 to Hoist hook 31 with M8 nut 47.
4. Insert Short drawstring 37 onto Hoist hook 31.
5. Fix Big pulley 29 to Moving pulley frame 8 with M10 \* 50mm bolt 40.

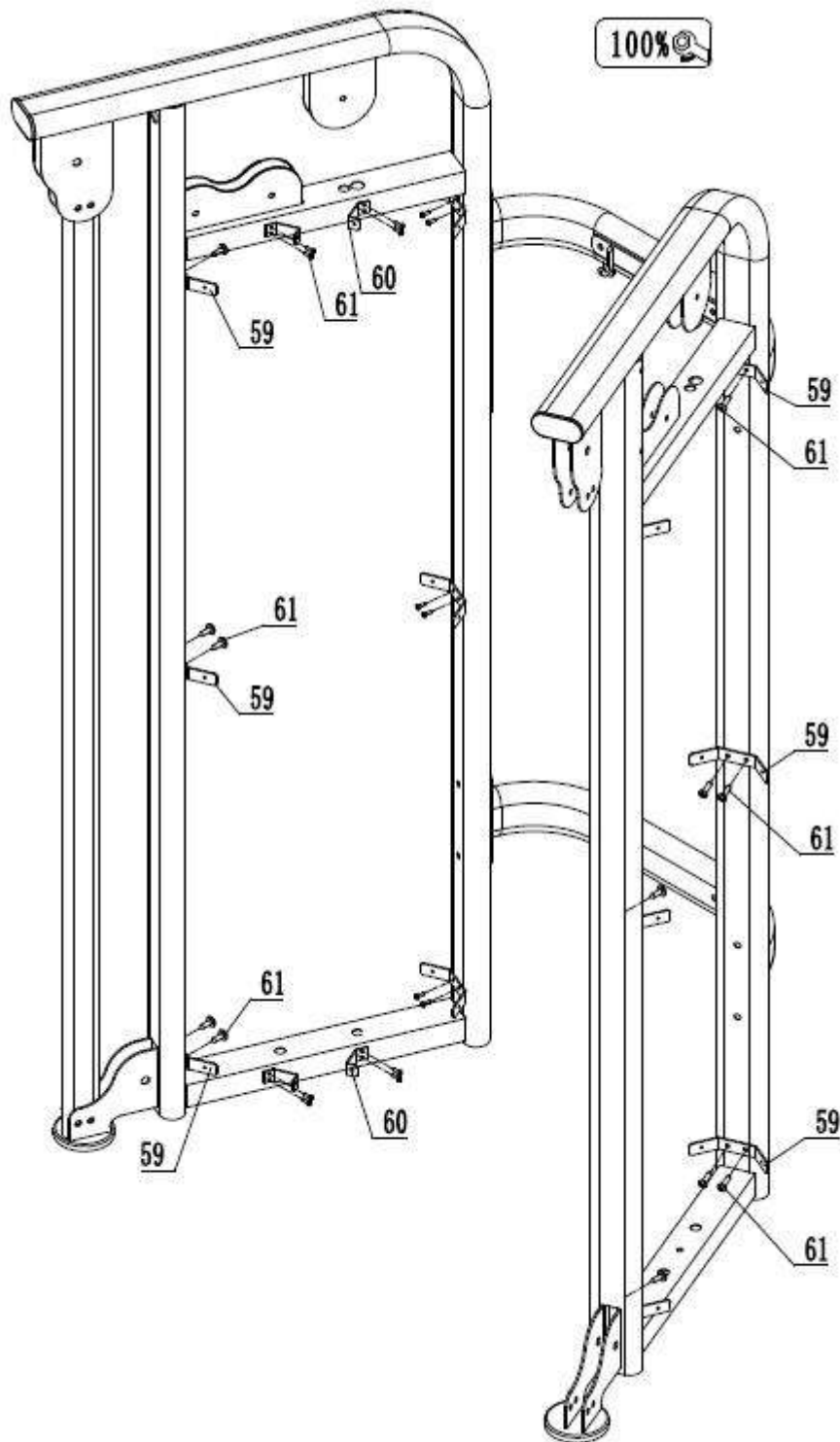

**STEP 5:**

Fix Cover support frame 59 and Cover up support frame 60 to Left main frame1 and Right main frame2 with 4.8\*16 Big cross head screw 61.

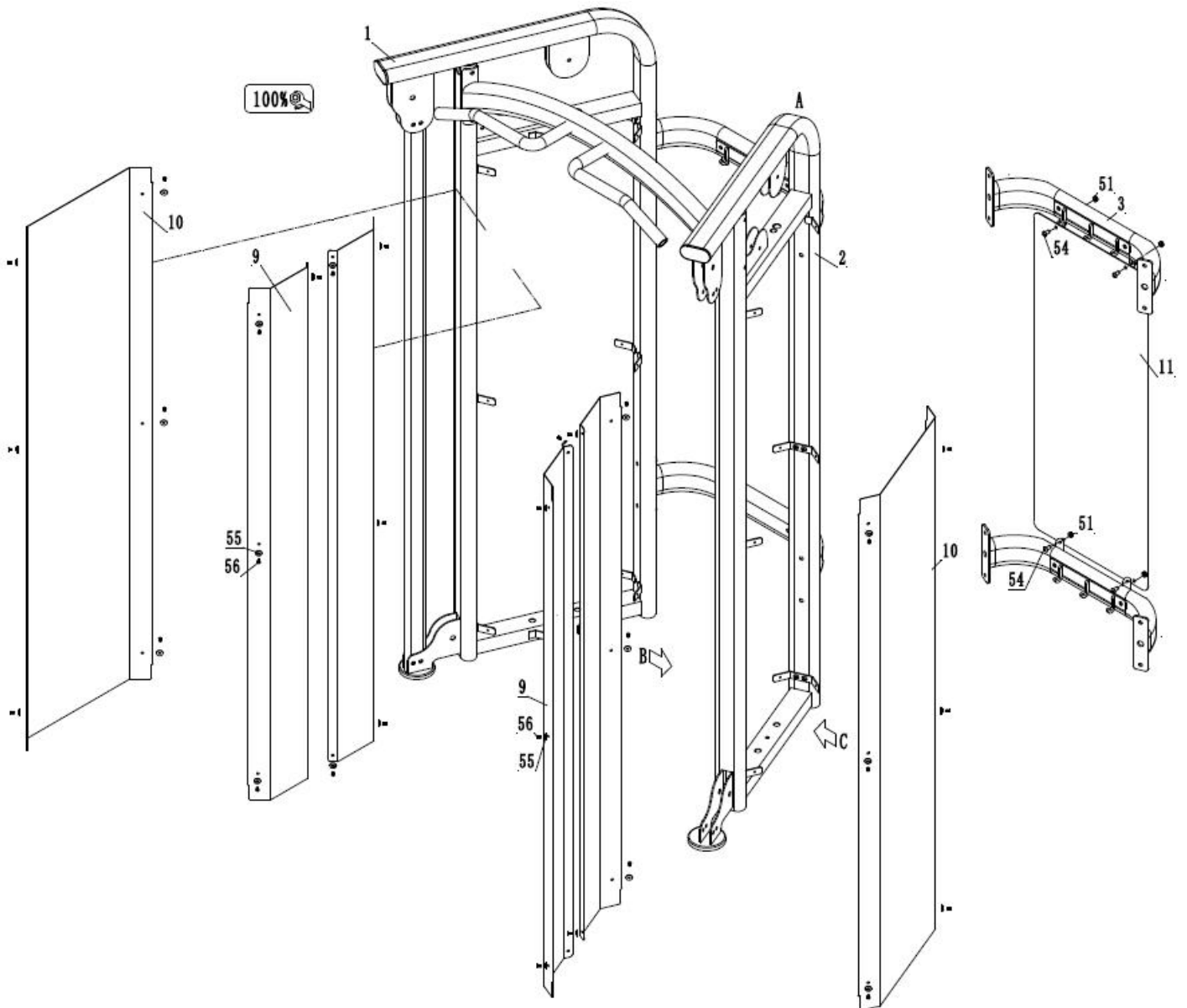

**STEP 6:**

1. Fix Middle cover 11 to Rear connect support 3 with M8\*15mm Allen head bolt 54 and M8 Nylon nut 51.
2. Fix Front cover 9 and Rear cover 10 to Left main frame 1 and Right main frame 2 with Plastic washer 55 and M5\*15mm Allen head bolt 56.