

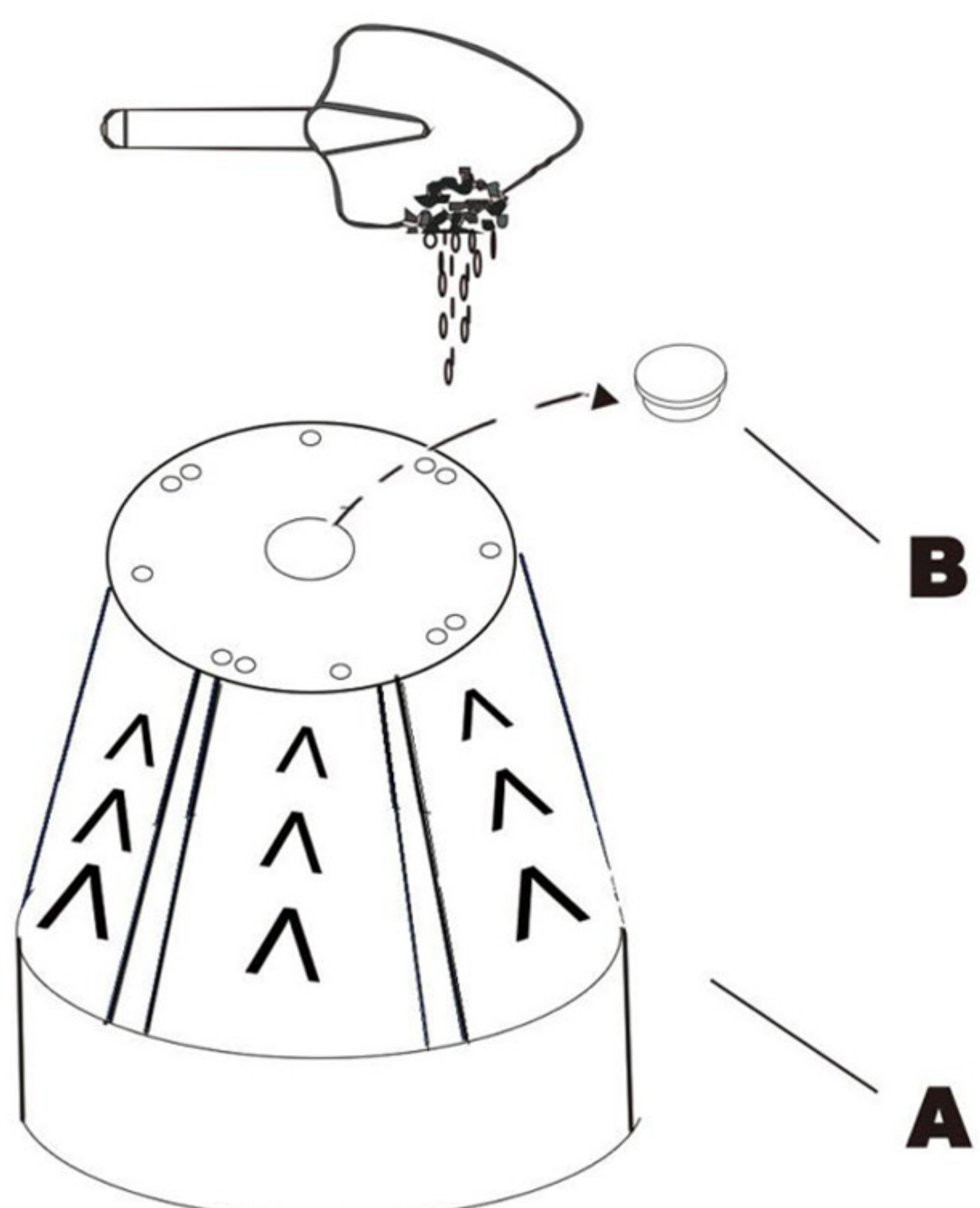

**HIT BOXING**  
**Rapid-Reflex**  
**Boxing Bar Tri-Bag**  
 Assembly Instructions  
 Item No.:HIT00349

It is important to install the spinning reflex bar first, before attaching the top target ball. If you need to remove the top target ball after attachment, first remove the round security clamp at the base of the spring, then twist the ball to the right until a pop sound is produced. Next, unscrew the ball to the left in the opposite direction to remove it. You can also use a pipe wrench to loosen and remove the top target ball.

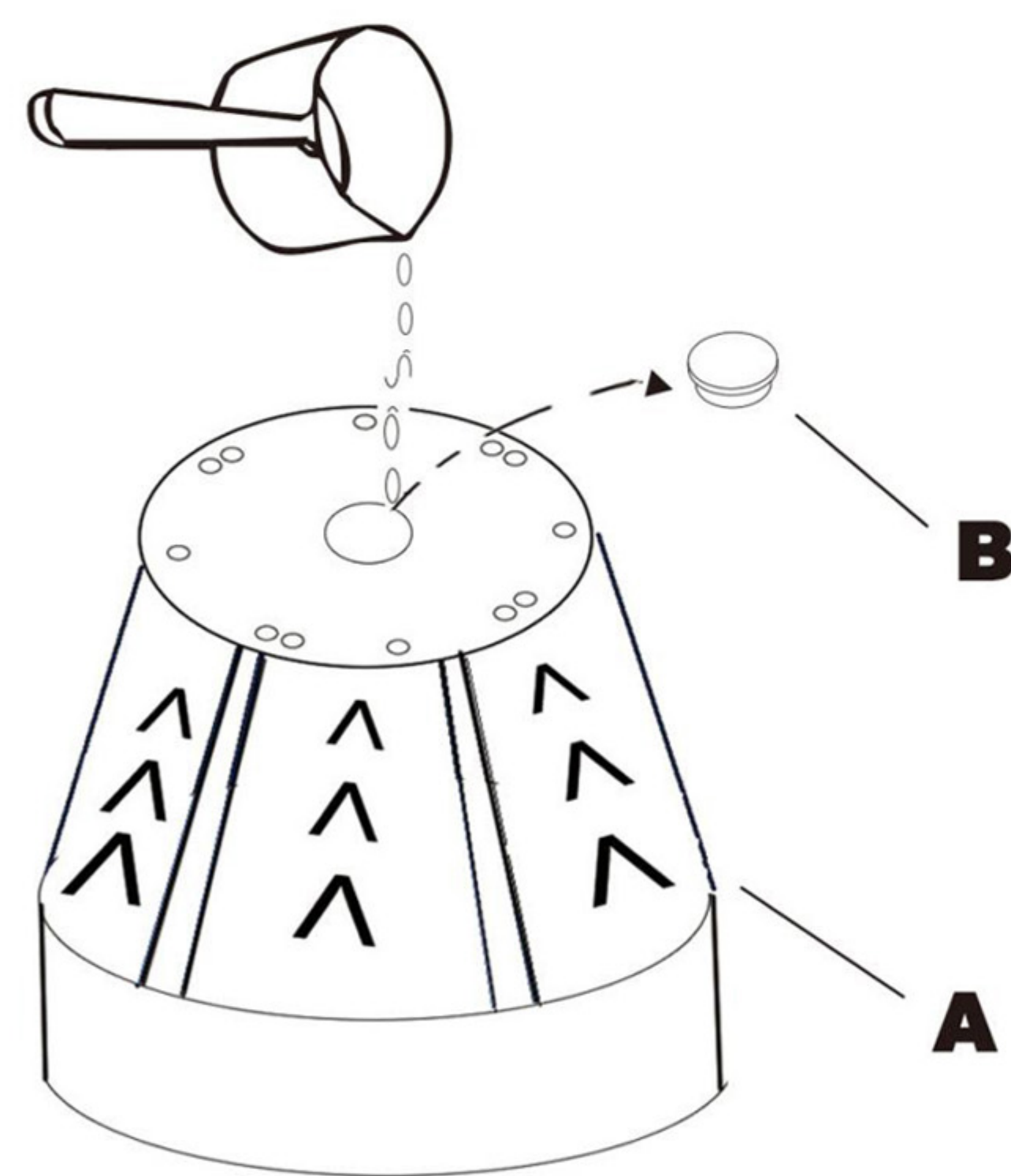
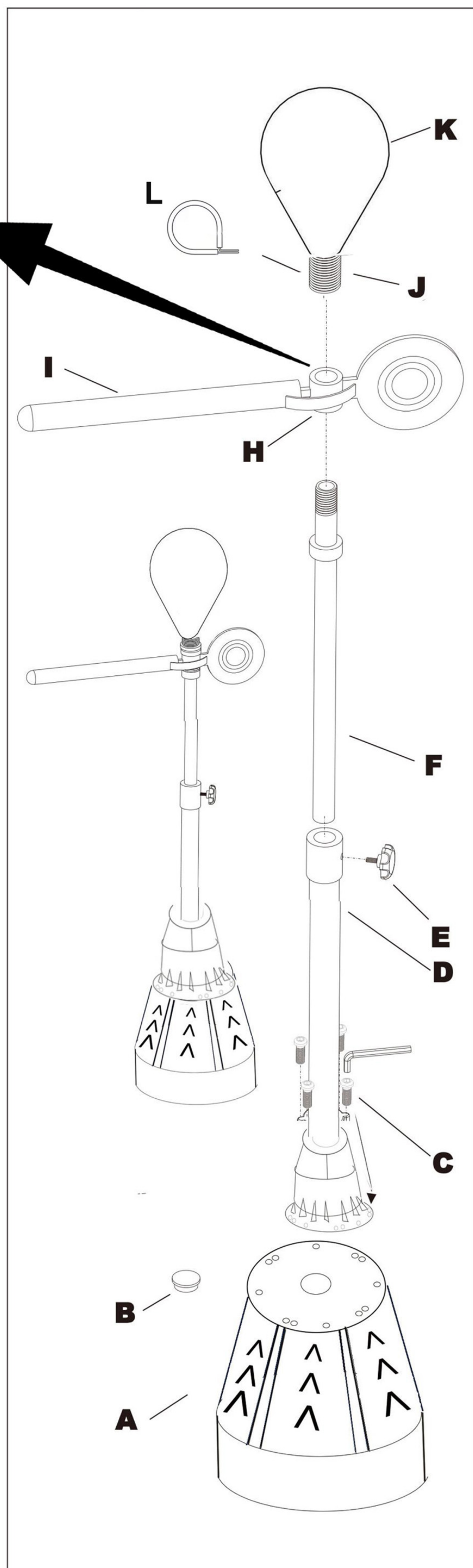

**HIT BOXING Rapid-Reflex Boxing Bar Tri-Bag**

**Step 1:** Fill the base (A) with water by removing the fill cap (B) and using a standard garden hose. If a hose is not available, use a funnel to help keep water from splashing outside the fill hole. After filling the base with water, replace the fill cap (B) securely back onto the base. The base can also be filled with sand, instead of water, for an even more stable training bag.

**Step 2:** Secure the bottom pole (D) onto the base (A) with the four screws (C) included.

**Step 3:** Insert the top pole (F) into the bottom pole (D), and adjust the height by using the turn knob (E).

**Step 4:** Install the Rapid-Reflex Spinning Bar (I) onto the top pole (F) through the round collar (H).

**Step 5:** Attach the top pear shape target ball (K) by securing the lower spring (J) into the round collar (H) on the spinning bar (I).

**Step 6:** Attach the round security clamp (L) around the base of the pear shape target ball lower spring (J) and fasten tightly.

The Rapid Reflex Boxing Bar Tri-Bag is now ready for use.

You can easily adjust the height of the target ball (K) and spinning bar (I) together by using the turn knob (E) on the bottom pole (D). The bag can also be more conveniently moved by tilting so the base is at about a 45-degree angle, and rolling the bag to and from the workout area, keeping it out of the way when not in use.

**WARNING:**

- Check the unit before every use to assure it is stable and in excellent condition, with no loose parts or connections.
- Check the target bag, and spinning reflex bar connections before every use for security, wear and tear and proper functionality.
- Always consult a physician before beginning any workout and exercise program.
- It is recommended that you always wear hand wraps and well-padded bag gloves when hitting and training on this bag.
- Always keep the area around the bag and spinning and reflex bar clear of all objects before every use.